

# Sustainable Design, Construction and Land Development

## *Guidelines for the Southeast*



## DOCUMENT AVAILABILITY

Reports produced after January 1, 1996, are generally available free via the U.S. Department of Energy (DOE) Information Bridge.

**Web site** <http://www.osti.gov/bridge>

Reports produced before January 1, 1996, may be purchased by members of the public from the following source.

National Technical Information Service  
5285 Port Royal Road  
Springfield, VA 22161  
**Telephone** 703-605-6000 (1-800-553-6847)  
**TDD** 703-487-4639  
**Fax** 703-605-6900  
**E-mail** [info@ntis.fedworld.gov](mailto:info@ntis.fedworld.gov)  
**Web site** <http://www.ntis.gov/support/ordernowabout.htm>

Reports are available to DOE employees, DOE contractors, Energy Technology Data Exchange (ETDE) representatives, and International Nuclear Information System (INIS) representatives from the following source.

Office of Scientific and Technical Information  
P.O. Box 62  
Oak Ridge, TN 37831  
**Telephone** 865-576-8401  
**Fax** 865-576-5728  
**E-mail** [reports@adonis.osti.gov](mailto:reports@adonis.osti.gov)  
**Web site** <http://www.osti.gov/contact.html>

This report was prepared as an account of work sponsored by an agency of the United States Government. Neither the United States government nor any agency thereof, nor any of their employees, makes any warranty, express or implied, or assumes any legal liability or responsibility for the accuracy, completeness, or usefulness of any information, apparatus, product, or process disclosed, or represents that its use would not infringe privately owned rights. Reference herein to any specific commercial product, process, or service by trade name, trademark, manufacturer, or otherwise, does not necessarily constitute or imply its endorsement, recommendation, or favoring by the United States Government or any agency thereof. The views and opinions of authors expressed herein do not necessarily state or reflect those of the United States Government or any agency thereof.

---

# **Sustainable Design, Construction, and Land Development**

---

## *Guidelines for the Southeast*

Walter Brown  
Southface Energy Institute

August 2000

Prepared by  
Southface Energy Institute  
Atlanta, Georgia  
under subcontract 86X-SV044V

Prepared for the Energy Division  
Oak Ridge National Laboratory  
Oak Ridge, Tennessee 37831-6285  
managed by UT-Battelle, LLC  
for the  
U.S. Department of Energy  
under contract DE-AC05-00OR22725



# Sustainable Design, Construction and Land Development

---

## *Guidelines for the Southeast*

Acknowledgments .....	v
List of Abbreviations .....	vii
<b>Introduction</b>	
<b>Creating Sustainable Communities .....</b>	<b>1</b>
<b>Chapter 1</b>	
<b>Sustainable Land Use Planning .....</b>	<b>5</b>
Practice 1: Preserve Open Space and Create More Compact Communities .....	8
Practice 2: Create Mixed-Use, Walkable Communities .....	12
Practice 3: Encourage Environmentally Based Land Use Plans and Walkable Community Zoning Ordinances .....	14
Practice 4: Encourage Urban In-fill and Brownfield Redevelopment .....	15
Practice 5: Create Sustainable Master-Planned Communities .....	17
Practice 6: Develop a Smart Growth Plan for Your Community .....	18
<b>Chapter 2</b>	
<b>Sustainable Site Development .....</b>	<b>21</b>
Practice 1: Create Subdivisions That Preserve Open Space .....	22
Practice 2: Survey and Consider the Environmental Features of Your Site .....	26
Practice 3: Minimize Soil Disturbance and Compaction during Construction .....	28
Practice 4: Control Erosion and Sedimentation during Construction .....	29
Practice 5: Protect Trees during Site Clearing and Construction .....	31
Practice 6: Use Landscaping for Energy and Water Efficiency .....	34
Practice 7: Manage Stormwater Naturally .....	37
Practice 8: Reduce Irrigation Needs by Harvesting Water on Site .....	40
Practice 9: Promote Environmental Awareness and Stewardship .....	42
<b>Chapter 3</b>	
<b>Sustainable Buildings: Floor Planning, Indoor Air Quality, Material Selection, and Waste Reduction .....</b>	<b>43</b>
Practice 1: Create Efficient Floor Plans .....	44
Practice 2: Orient Buildings and Windows for Passive Solar Heating, Cooling, and Daylighting .....	46
Practice 3: Specify Sustainable and Healthful Building Materials .....	48
Practice 4: Design Interiors That Ensure Healthy Indoor Air Quality .....	52
Practice 5: Prevent Moisture, Radon, and Soil Gases from Entering Homes .....	54
Practice 6: Reduce Job-Site Waste and Use Building Materials Efficiently .....	56

<b>Chapter 4</b>	
<b>Sustainable Buildings: Energy-Efficient Design and Construction</b>	59
Practice 1: Create a Continuous Air Barrier	61
Practice 2: Create a Continuous Insulation Barrier	64
Practice 3: Specify Properly Sized High-Efficiency HVAC Equipment	67
Practice 4: Design and Install Ductwork and Filters Properly	69
Practice 5: Prevent Interior Moisture Buildup with Controlled Ventilation	71
Practice 6: Specify Energy-Efficient Windows and Doors	72
Practice 7: Install Energy-Efficient Water Heating	74
Practice 8: Design Energy-Efficient Lighting	75
Practice 9: Specify High-Quality, Water-Saving Faucets and Fixtures	77
Practice 10: Specify Energy-Efficient Refrigerators and Appliances	78
<b>Appendix A</b>	
Sources and Additional Resources	81
<b>Appendix B</b>	
Green Builder Programs, Energy-Efficient Mortgages, and Third-Party Certification	93
<b>Appendix C</b>	
EarthCraft House <sup>SM</sup> —Worksheet	97

# Acknowledgments

## Research Assistants:

Allison Akerman  
Amanda Baranski  
Jonathan Bebb  
Winton Brazil  
Natalie Brown  
Jason Duvall  
Sandra Estrada  
John Fyfe  
Mirko Rados  
Elizabeth Whyte

## Editors:

Julie Simon, Southface  
Carolyn Moser, ORNL

## Publication design and layout

Greg Brough  
Alicia Jacobs

## Reviewers:

Mike Barcik, Southface Energy Institute (Atlanta, GA)  
Stephanie Busch, Georgia Pollution Prevention Assistance Division (Atlanta, GA)  
Dennis Creech, Southface Energy Institute (Atlanta, GA)  
Mary Jim Evans, Winter Construction (Atlanta, GA)  
Bruce Ferguson, University of Georgia (Athens, GA)  
Thomas Fisher, Environmental Design Collaborative (Charlottesville, VA)  
Laurie Fowler, University of Georgia (Athens, GA)  
Stephen Macauley, Macauley Properties, Ltd. (Marietta, GA)  
Randy Pimsler, Pimsler Hoss Architects (Atlanta, GA)  
Clayton Preston, Village Habitat Design (Atlanta, GA)  
Polly Sattler, Southface Energy Institute (Atlanta, GA)  
Pam Sessions, Hedgewood Properties (Cumming, GA)  
Jeff Tiller, Southface Energy Institute (Boone, NC)  
Alex Wilson, Environmental Building News (Brattleboro, VT)

## Sponsors:

This publication was produced by the Southface Energy Institute with support from the Alabama Department of Economic and Community Affairs, Georgia Environmental Facilities Authority, Oak Ridge National Laboratory, the U.S. Department of Energy, the U.S. Environmental Protection Agency, and grants from the Turner Foundation and Larry Thorpe.

## A special thanks to . . .

*Jack Crowley for his cityscape illustration on the cover*





# List of Abbreviations

ACCA	Air Conditioning Contractors of America
ACH	air changes per hour
AFU	annual fuel utilization efficiency
ASHRAE	American Society of Heating, Refrigerating, and Air-Conditioning Engineers
ASTM	American Society for Testing and Materials
CFC	chlorofluorocarbon
CFL	compact fluorescent lamps
cfm	cubic feet per minute
CRI	color-rendering index
DOE	U.S. Department of Energy
EPA	U.S. Environmental Protection Agency
HCFC	hydrochlorofluorocarbon
HFC	hydrofluorocarbon
HSPF	heating season performance factor
HVAC	heating, ventilating, and air-conditioning
IAQ	indoor air quality
IC	insulation coverage
ICF	insulated concrete form
MEC	Model Energy Code
NFRC	National Fenestration Rating Council
OSB	oriented strand board
OVE	optimum value engineering
psi	pounds per square inch
PVC	polyvinylchloride
SEER	seasonal energy efficiency ratio
SIP	structural insulated panel
TDR	Transfer of Development Rights
TND	Traditional Neighborhood Development
VOC	volatile organic compound



## INTRODUCTION

# Creating Sustainable Communities

**S**prawling growth in the Southeast is degrading the region's air quality, water resources, open space, natural systems, and general quality of life. It costs everyone more for sprawl development than for compact, sustainable development. For developers and builders, direct costs are higher for permitting, waste disposal, and infrastructure. Environmental problems also produce negative publicity and reduce the attractiveness of a particular development or even an entire community to real estate investors, corporations, and families. For governments, higher infrastructure and environmental protection costs lead to higher taxes.

Meanwhile, the general public is gaining understanding of the downsides—ranging from traffic congestion to children's allergies to higher taxes—of sprawl growth and standard building practices. In some communities, an anti-growth backlash is emerging from citizens tired of dirty air, polluted streams, and loss of natural areas. Federal, state, and local governments are responding to the environmental problems created by growth in many communities, but the pace of improvement from government solutions—whether collaborative or regulatory—is slow.



Southface Photo

But the news is not all bad. Knowledge about sustainable development and green building practices and materials is growing, as is the public's willingness to buy green products. Green building programs emphasizing energy and resource efficiency and environmental responsibility are spreading throughout the country—some of them supported by the nation's largest builders. Rather than waiting until government steps in, savvy developers and builders can respond directly to consumer concerns about the environment and quality of life. Those that do will capture a growing market and help make communities both more desirable and sustainable.

By asking the following questions, those responsible for carrying out development and consumers selecting places to live can ultimately create a sustainable future for our communities:

- ✓ Does the development maximize use of existing infrastructure and minimize new infrastructure?
- ✓ Does the development minimize dependence on the automobile and promote other forms of transportation?
- ✓ Will the development form a livable and long-lasting community?
- ✓ Does design promote social interaction and places for random encounters?
- ✓ Were natural habitats, watersheds, and fertile soil resources preserved during and after construction?
- ✓ Were productive farmlands and cultural resources preserved?
- ✓ Are homes and other buildings in the development energy efficient?
- ✓ Were building materials used efficiently?
- ✓ Were renewable building resources used?
- ✓ Were construction waste products recycled during construction?
- ✓ Were healthy building materials used?
- ✓ Are buildings sturdy, adaptable, and of high quality?

## Benefits of sustainable development

Sustainable development is development that allows for economic well-being, environmental protection, and overall quality of life for people today without compromising the ability of future generations to meet these needs. Everyone benefits from an environmentally sensitive approach to growth and development. The following summary lists some of the benefits different constituencies gain from sustainable development:

### Citizens/ Taxpayers

- More affordable and energy-efficient housing
- Reduced utility costs
- Cleaner water and air
- Reduced commuting time
- Improved quality of life
- Increased durability of housing
- Improved health
- More secure home investments
- Lower infrastructure operating and replacement costs
- More tax resources available for improved schools and public facilities

### Builders and developers

- Competitive advantages from building green
- Improved image and public goodwill
- Reduced land and infrastructure costs
- Fewer consumer complaints
- Fewer regulatory hassles
- Healthier construction conditions

### Lenders/ Realtors

- Expanded markets
- Improved resale values
- Reduced foreclosure risks
- Improved image and public goodwill
- Increased competitive advantages
- Access to secondary market financing incentives

Local governments, regulatory and economic development agencies

- Increased tax base
- Reduced service delivery costs
- Competitive advantage over areas with lower quality of life
- Reduced need for additional roads and infrastructure
- Extended life of existing schools and public facilities
- Reduced need for additional power plants
- Increased life of existing land and water resource base
- Reduced cost of water purification and sewage treatment
- Extended life of existing landfills
- Protected natural resources

- Preserved agricultural resources
- Increased economic diversity
- Increased housing affordability
- Relief from federal regulations

---

*A 1992 Rutgers University Study found that in comparing compact development versus sprawl development in New Jersey over a 20-year period, growth rates were equal but the compact developments saved \$1.3 billion in infrastructure costs and 30,000 acres of farmland.*

---



Photo courtesy of Walkable Communities, Inc.

## How to use this guide

This guidebook provides basic information about better land use techniques, creating land-conserving subdivisions, using green building materials, and the latest energy- and resource-efficient building technologies. While many topics covered are applicable to all forms of land development and building, this publication is primarily focused on residential development and construction. Each chapter of the guide is organized into practices, each of which is designed to lay a foundation on a particular topic. The information, studies, and other resources used to develop the chapters are included in Appendix A under the heading “Sources.” Additional resources are also listed in Appendix A to point the reader to resources for further information and implementation.

---

### Sustainable Building Priority Check List

- *Save energy*—~~Design and build energy-efficient buildings.~~
- *Recycle buildings*—~~Utilize existing buildings and infrastructure instead of developing open space.~~
- *Create community*—~~Design communities to reduce dependence on the automobile and to foster a sense of community.~~
- *Reduce material use*—~~Optimize design to make use of smaller spaces and utilize materials efficiently.~~
- *Protect and enhance the site*—~~Preserve or restore local ecosystems and biodiversity.~~
- *Use low-impact materials*—~~Specify low-environmental-impact, resource-efficient materials.~~
- *Maximize longevity*—~~Design for durability and adaptability.~~
- *Save water*—~~Design buildings and landscapes that are water-efficient.~~
- *Make the building healthy*—~~Provide a safe and comfortable indoor environment.~~
- *Minimize construction and demolition waste*—~~Return, reuse, and recycle job-site waste and practice environmentalism in your business.~~
- *Green up your business*—~~Minimize the environmental impact of your own business practices, and spread the word.~~

(Alex Wilson and Nadav Malin, “Establishing Priorities with Green Building,” *Environmental Building News*, September/ October 1995.)

---

## CHAPTER ONE

# Sustainable Land Use Planning

### Introduction

The enviable growth in the southeastern economy has been fueled in part by the rapid conversion of raw land into housing, roads, and businesses during a period dominated by the automobile and sprawl-style development. Developers, environmentalists, and regulators have become increasingly confrontational about the causes and effects of rapid growth and loss of green space. The Atlanta region, in particular, has begun to suffer from negative news about its congestion and related air-quality problems. One result is that several national real estate trend setters have downgraded Atlanta as a real estate market.

Yet growth pressure on new areas, far from the community center, will continue unless deterioration in older areas, land use planning, and transportation options are addressed together with sustainability in mind. Clearly, the kind of development occurring in the Southeast and throughout the United States—separated use, automobile-oriented sprawl—has costly downsides.



### Rapid growth disrupts tax bases

School choice and personal safety issues often lead homebuyers to leave one community behind and tolerate longer commutes to live where they perceive their families will thrive. Unfortunately, movement patterns like this cause significant tax base disruptions, declines in the quality of public schools and public services, high costs associated with creating duplicative services in the new places, loss of green space, *and* eventual abandonment and blight of suburban areas within a single generation. Montgomery County, Maryland, for example, recently found that during the same period it financed and built 60 new schools, 60 older schools closed as a result of shifting settlement patterns within its jurisdiction.

### Low-density growth increases infrastructure costs

Low-density sprawl is costing local governments and taxpayers a fortune to maintain miles of streets and public infrastructure that meander across counties. Sprawl development is a temporary boon to growth-oriented counties but can quickly outlive its financial benefits.

### Sprawl causes loss of economic diversity

Studies show that low-density residential development rarely pays for itself in terms of services demanded. In Loudoun County, Virginia, only housing valued at \$400,000 or higher was found to raise enough property tax to equal service delivery costs. Counties tend to discourage affordable housing, especially housing accommodating many school-aged children, because of the higher costs of providing services. Such revenue-driven policies conflict with social equity issues as well as the needs of small business owners requiring access to low-cost labor.

### Congestion can result in loss of federal resources

Regulatory penalties are a significant downside to uncontrolled growth. As a result of extremely poor air quality associated with congestion caused by sprawl development, the entire Atlanta region is currently ineligible for new federal highway funding. Communities that do not yet suffer from the congestion and air quality problems facing Atlanta can avoid loss of resources by implementing more sustainable development patterns.

### Sprawl growth can cause a decline in regional quality of life and long-term economics

Perceptions about the quality of life of an entire region contribute to or detract significantly from the long-term economic prospects of a region. A recent national real estate survey found that the Atlanta metropolitan region no longer fits the profile of an urban area that has a high quality of life. Lacking in significant “24-hour city” qualities in its declining urban center, and having lost much of the original rural character that attracted migrants to the region’s suburbs, the Atlanta region has declined in rank from 1 to 16 in a 1999 real estate investment survey by Lend Lease Real Estate Investment Company.

### Rapid growth causes loss of farmland and wildlife habitat

The rapid suburbanization of land around cities has had a tremendous impact on the family farm and on wildlife. As fields and woods are converted into subdivisions, habitats can become fractured, streams may lose their ability to support healthy fish populations, and once open pastures and farm fields no longer provide relief from the fast-paced life of our cities.



## What can be done about it

To mitigate or balance growth pressures on a regional basis, communities must find ways to make older areas more desirable and require new areas to bear more fully the environmental and economic costs of their development. The term “smart growth” has caught on recently to describe a concept that favors environmentally sustainable growth. By use of a well-managed set of sustainable land planning practices, development can continue to provide economic rewards with fewer social and environmental downsides.

## A Summary of Sustainable Land Use Planning Practices

- ✓ Preserve open space and create more compact communities
- ✓ Create mixed-use, walkable communities
- ✓ Encourage environmentally based land use plans and walkable community zoning ordinances
- ✓ Encourage urban in-fill and brownfield redevelopment
- ✓ Create sustainable master-planned communities
- ✓ Develop a smart growth plan for your community

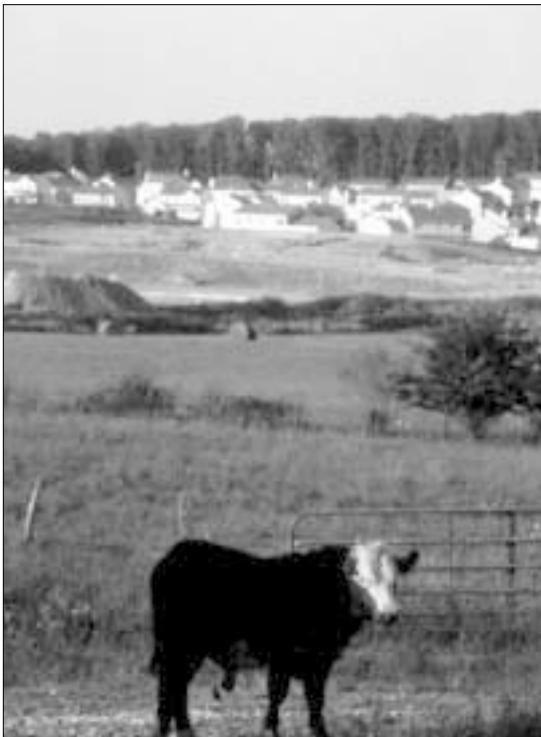

Photo by Tricia Obester, courtesy of American Farmlands Trust

*According to a recent report of the American Farmland Trust, a nonprofit organization working on preserving threatened agricultural lands in the United States, 79% of the nation’s fruits, 69% of its vegetables, and 52% of its dairy goods are now produced on high-quality farmland threatened by sprawl. With the U.S. population expected to jump 50% by the mid-21st century and high-quality farmland projected to shrink 13% within the next 60 years, the nation could become a net food importer instead of a net food exporter.*



## Practice 1

# Preserve Open Space and Create More Compact Communities

### Why this practice is important

A recent study found that the Atlanta metropolitan region is sprawling outward faster than any other region in the world today. For every 1% increase in population in the Atlanta region, an estimated 16% more land area is placed under development. As a result, Atlantans drive more miles per capita (34 miles a day) than in any other place in America, while the region loses open space and wildlife habitat at an alarming rate.

### The solution and its benefits

To stop wasteful land use patterns, communities can immediately strive to create more compact, more fully functional places that are sustainable from a cultural, economic, and environmental perspective. Even if individuals or families chose not to move back into the city, as many are now doing, everyone can develop, build in, or select a home in a well-planned community that has lasting qualities.

Benefits of more compact development include

- Infrastructure cost reductions**  
 According to recent studies, the cost per dwelling unit for streets, utilities, and schools drops dramatically when density increases from rural to urban densities. Streets can cost  $\frac{1}{13}$  as much, utility systems cost  $\frac{1}{18}$  as much, and school construction costs  $\frac{1}{4}$  as much. Even small increases in density can cut infrastructure costs by as much as 35%. A change from 3 units per acre to 12 units per acre can yield
  - a 35% reduction in infrastructure costs (\$27,500 per unit vs. \$42,500 per unit for streets, utilities, and schools) and
  - a 10% reduction in total energy costs per household, or about \$500 less including home and transportation costs
- Pollution prevention**  
 Denser, mixed-use development requires far less transportation energy, resulting in less ground-level air pollution and fewer greenhouse gas emissions—as much as 15 tons less carbon dioxide per year for each family. If we combine transportation, home, and a portion of community facility needs (office, shops, etc.), the typical low-density household uses nearly 40% more energy per year than a high-density urban household, resulting in 40% more air pollution.

- **Creation of stable communities**

More compact, pedestrian-friendly communities offer many other benefits, including collective security, greater interaction with neighbors, lower government service costs, and communities that maintain their quality of life, property values, and tax base.

### Here's What You Can Do

Reversing the effects of sprawl development will require new planning tools and a lot of public education. Land preservation tools vary from high levels of government control to marketplace mechanisms. Many areas of the country have employed these tools to begin implementing alternatives to sprawl development:

- ✓ **Offsetting density strategies**

To encourage protection of valuable open space or to create watershed buffers and greenways, many communities have turned to negotiating with developers seeking land use changes or zoning variances. In exchange for greater density on one portion of their land, developers agree to permanently set aside open space. The same number of units overall is achieved on less land.

- ✓ **Transfer of Development Rights (TDR)**

TDR allows a developer to increase the density of development on one piece of land by paying to preserve open space in another part of the district. Generally, TDR programs are established under local zoning ordinances. In the context of farmland protection, TDR is used to shift development from agricultural areas to designated growth zones closer to municipal services. The parcel of land where the rights originate is called the “sending” parcel. When the rights are transferred from a sending parcel, the land is restricted with a permanent conservation easement. The parcel of land to which the rights are transferred is called the “receiving” parcel. In Montgomery County, Maryland (similar in size and population to Cobb County, Georgia), where nearly

---

*Cherokee County, Georgia, is trying to retain its rural character in the path of the North Atlanta expansion wave. To create more sustainable growth and to protect open spaces, the county has encouraged both a town-center style of development and the use of an offsetting density strategy that allows developers to increase density in exchange for protecting open spaces. In one example, a developer won approval to build 370 homes on only 45 acres of land (about 10 units per acre when roads are subtracted ) in exchange for agreeing to set aside 30 acres for natural areas and trails. However, many area residents fought this new subdivision because it varied from their concept of how to slow growth by lowering density.*

---

one-third of rural land and forests have been preserved through an ongoing commitment to land preservation using TDR and other mechanisms, the owner of a sending parcel maintains the right to develop one unit per 25 acres plus one additional unit for each child. The county considers this approach fair to landowners, and at one unit per 25 acres, the open-space character of the protected area is not threatened. In 1998, Georgia passed a bill authorizing local governments to adopt TDR programs. Other states using TDRs include New Jersey, Florida, and California.

- ✓ **Agricultural and conservation easements**

Agricultural or conservation easement purchase programs enable landowners to separate and sell away their right to develop land from their other property rights. The easement buyer receives the right to ensure that the land remains either agricultural or otherwise undeveloped. After selling

an easement, the landowner retains all other rights of ownership, including the right to enjoy its natural beauty, prevent trespass, sell, bequeath, or otherwise transfer the land. Land developers can use easements as a way to permanently set aside portions of their developments as open space in exchange for increased density on a portion of their parcel. Generally, there must be a nonprofit or governmental entity available to “purchase” or accept conservation easements in order to permanently protect and maintain the easement.

#### ✓ Land trusts

An effective private sector strategy to preserve open space is through the creation of land trusts established to acquire and protect open or wild lands in perpetuity. Land trusts usually operate in a particular area that has been exposed to growth pressure or the threat of losing a locally valued natural asset. Land trusts can either seek to own property outright or purchase conservation easements from willing sellers. The Nature Conservancy is a large national land trust that owns and protects hundreds of thousands of acres of wild lands on behalf of its many members and contributors.

#### ✓ Traditional Neighborhood Development (TND)

As the name implies, TND suggests a return to the kinds of neighborhoods built before the Second World War, when the automobile did not dominate the landscape. With TND, towns and cities are composed of neighborhoods in which people can live, work, and play. All neighborhoods have well-defined town centers and provide a mixture of amenities that include parks, bikeways, sidewalks, and walkable shopping areas. The following are basic TND principles:

- All lots are readily accessible to local retail and recreation on foot or by bicycle (a distance not greater than ¼ mile).

---

#### Communities and Organizations Dedicated to Sustainable Growth

*Seaside, Florida, and other kindred developments such as Harbor Place in Memphis, Tennessee, recently spawned a new movement in city planning known as New Urbanism. The Congress of New Urbanism was formed by Peter Katz, Peter Calthorpe, Andreas Duany, Elizabeth Plater-Zyberk, and other architects, planners, and developers committed to a proposition that new American communities should be developed to be both a visual delight and a place for people, not just cars. New Urbanists believe that towns can be built that create a sense of place and that become cherished communities worth the trouble and resources invested in them.*



*Belmont, North Carolina, located just south of booming Charlotte, recently passed a new zoning ordinance known as Traditional Neighborhood Development. The ordinance allows for development of mixed-use, pedestrian-oriented neighborhoods.*

- 
- Housing types are mixed and in close proximity to one another.
  - Street networks are interconnected, blocks are short (around 200 feet), and street widths are minimized.
  - Building setbacks from the street are reduced and building fronts incorporate porches and other gathering places.
  - Civic buildings are given prominent sites throughout the neighborhood.

- Parking areas and garages are placed at the back of buildings or lots.
- Neighborhoods are a minimum of 50 acres and less than 200 acres.

TND has the potential to use less than a third of the land area required for the average suburban developments. A typical 350-home subdivision requires approximately 100 acres for building lots, streets, and utilities, with no significant amount of open space preserved. A development of the same size using a TND model preserves about 20% of the land for open or natural areas and more than doubles the number of residents.

✓ **Transit-oriented development**

Most early American cities grew along trolley or rail lines. The automobile changed that pattern in the 1950s, when the era of low-density sprawl development began. Planners are revisiting development where transit links communities and permits higher-density developments that make the most efficient use of land and use the least energy.

✓ **Public land acquisition**

Many communities faced with rapid growth and water quality concerns resort to outright purchases of valuable open lands. While often costly, a permanent revenue source tied to real estate transfer taxes (or another source) can be effective. At the same time, local government concern about loss of the property tax base is usually unwarranted. The value of land adjacent to permanently protected natural areas typically increases in value. In the long run, the entire area benefits from quality-of-life improvements that can set a city or county apart from its competitors.

✓ **Urban growth boundaries**

Portland, Oregon, is perhaps the country's most aggressive fighter of urban sprawl. Portland established a boundary that defines where housing or commercial developments can occur. Outside the boundary, agricultural and open

---

*The Metropolitan Atlanta Rapid Transit Authority (MARTA) is preparing to build an entire new "town" around one of its major transit stations.*

*This new "24-hour" city will include office, retail, hotel, apartment, and condominium space built around a rail station with direct access to downtown Atlanta and the airport. Car ownership will be optional. The potential energy and pollution savings are dramatic.*



*The city of Atlanta is operating its wastewater treatment system under a 1998 Federal Court consent decree resulting from a lawsuit brought against the city under the Clean Water Act. One provision in the decree requires that Atlanta commit to spending \$25 million during the next 8 years for the purchase of natural buffers and greenways along streams in the city.*



*How do you pack 700,000 more people into just 20,000 more acres? That's the question facing planners drawing up Region 2040, a sprawl control plan for Portland, Oregon. The plan being considered by the Metro Council means Portland will see areas of high-density development over the next 45 years. While the regional population of 1.3 million is expected to increase by 55%, just 8% more land would be added to the Urban Growth Boundary.*

---

spaces cannot be developed. Portland created the Metro Council to require regional cooperation of all jurisdictions throughout Clackamas County.



*Tree-lined streets invite pedestrian traffic by offering shade and buffering from automobiles.*

## Practice 2

# Create Mixed-Use, Walkable Communities

### Why this practice is important

Modern zoning ordinances separate land uses to “protect” citizens from commercial or industrial land uses incompatible with residential neighborhoods. Such zoning has helped create modern sprawl, making an automobile necessary for even the shortest trips.

Most shopping is located on busy arterial streets that cannot be reached safely on foot from a residential area. Even pedestrian access from one strip center to the other is difficult or impossible. Offices and entertainment are even further removed. Multifamily housing is built as far away as possible from single family to “protect” property and family values. The result is congestion, visual clutter, loss of free time, and social inequity.

### The solution and its benefits

Mixing housing, retail space, and offices reduces energy use, land consumption, stormwater runoff, urban heat island effects, and vehicle miles traveled. Including restaurants, coffee shops, dry cleaners, and other services in the mix creates a more urban setting. The ultimate goal of mixing uses is to create a destination place that begins to function like a traditional town center.

In particular, when jobs and housing are evenly mixed and closely located,

- Energy use can go down by 2.7 trillion Btu per acre per year, a savings of about \$25,000 annually
- Approximately 240 tons of carbon dioxide per acre is saved each year
- Vehicle trip miles are reduced by at least 50%, greatly reducing air pollution

## Here's What You Can Do

- ✓ Combine commercial and residential development where possible and mix sizes and types of housing.
- ✓ Move commercial buildings close to the street, creating a “streetwall,” and reduce residential setbacks.
- ✓ Locate parking both on-street and at the rear of buildings. Use shared parking.
- ✓ Reduce street width for main and feeder streets.
- ✓ Create pedestrian-friendly crosswalks and sidewalks.
- ✓ Use landscaping and arcades to cool and entice pedestrians to walk between shops.
- ✓ Encourage structural change in zoning to encourage or require mixed-use development.



*“Parking lots exert a powerful undertow on local economies by taking up space that could be put to more profitable uses,” says John Shaw, assistant professor of urban and regional planning at the University of Iowa. Shaw cites several sources, including Richard Wilson and the Washington, D.C.-based COMSIS Corporation, that say each unused parking space wastes \$600 to \$900 a year in land development costs; vacant spaces in parking structures cost more. And these figures do not include potential tax revenues that are lost to parking each year.”*

(Lisa Wormser, “Don’t Even Think about Parking Here,” *Planning Magazine*, June 1997.)

## Practice 3

# Encourage Environmentally Based Land Use Plans and Walkable Community Zoning Ordinances

### Why this practice is important

Currently, many communities frustrated by rapid growth have adopted a land use plan that restricts housing development to a very low density level (such as 2-acre lots) in the hope of preventing urbanization of the area. Unfortunately, the result is an escalation of sprawl as houses become more spread out and infrastructure and roads eventually fill the county to its borders. Little or no open space is preserved for public enjoyment or environmental services.

### The solution and its benefits

Today, hundreds of communities across the country are looking at new land use plans that reduce reliance on the automobile. Whether in areas that can justify high density with transit or in smaller towns and urbanizing areas, a well-planned approach that results in central places and pedestrian access to community facilities should be the primary organizing principle.

By creating incentives for compact development in less environmentally sensitive areas, communities encourage preservation of open space. Preservation can be encouraged using Environmental Performance Zoning, which establishes areas the community wants to protect in exchange for permitting higher density on less sensitive sites.

### Benefits include

- Clearly defined open space, “no build” areas of the community
- Well-defined development patterns designed to encourage more pedestrian-friendly communities
- A basis for establishing TDR and other land preservation incentive programs
- Improved watersheds and wildlife habitat
- Improved opportunities for shared community spaces and recreation.

## Here's What You Can Do

- ✓ Support land use plans and development ordinances to encourage mixed-use, pedestrian-oriented development.
- ✓ Support development ordinances that permit and encourage offsetting density strategies.
- ✓ Support tree ordinances that protect and replenish significant tree canopies and require shade creation on parking lots.



## Encourage Urban In-fill and Brownfield Redevelopment

### Why this practice is important

Vast amounts of inner city land have been skipped over in the rapid suburbanization of America. Some inner city land is avoided because of perceptions about schools and crime; other locations may have environmental problems that are difficult and costly to overcome. Rural areas are often easier to develop than the abandoned, idle, or underused commercial or industrial lands, or brownfields, of cities and have less negative associations in the eyes of developers. The result is the destruction of open space *and* the abandonment of the inner city.

---

*Just twenty years ago, Chattanooga, Tennessee, was considered one of the dirtiest cities in America. A concerted effort begun in 1984 has completely turned Chattanooga around. The city made use of former brownfield sites, lining a once foul river with parks, an aquarium, and new commercial and residential development. Led by a tremendously diverse group of citizens, business leaders, government agency heads, nonprofit groups, and professional planners and designers, Chattanooga has put a new plan into play for the 21st century that it believes will make the city into the environmental showcase of the South.*

---

### The solution and its benefits

Cities and regional governments must create incentives to encourage development in or near the central city and on lands that require cleanup, known as brownfield sites, and this effort is now receiving federal attention. The U.S. Environmental Protection Agency (EPA) is trying to streamline the regulatory and legal barriers that have inhibited the redevelopment of these sites. Many urban core cities are creating so-called Empowerment Zones, Enterprise Zones, and local Tax Increment Finance districts to encourage in-fill and brownfield redevelopment. The EPA has also recognized the environmental hazards posed by sprawl development and is more committed than ever to seeing brownfield sites redeveloped.

Enormous energy savings and pollution reduction are possible when growth is directed back to the urban core. The financial health of the central city is still extremely important to the larger region. While new developments in the central city are sometimes viewed as economic competition for edge cities, this exciting new trend has the potential to greatly relieve growth pressure on rural lands at the fringe.

### Benefits include

- Development on previously disturbed lands and preservation of rural lands
- Reduction in new infrastructure costs
- Reinvestment in older infrastructure
- Reduction in vehicle trip miles
- An improved central city tax base
- Job creation



Photo courtesy of Jacoby Development, Inc.

*Atlantic Steel operated in downtown Atlanta, Georgia, for 100 years on a 138-acre site. Today, the mill is shut down and the abandoned factory buildings fill the northwestern skyline of Atlanta. Jacoby Development has recently proposed a new project that would create a 24-hour work, play, live-in community with a total of 12 million square feet of office, retail, entertainment, and residential space. If successfully developed, this single project could save thousands of acres of “greenfield” land that might be otherwise developed at standard urban fringe densities.*

## Here’s What You Can Do

- ✓ Seek out bypassed land in the urban core and suburbs with potential for “infill” development as well as underutilized or obsolete developments with potential for redevelopment.
- ✓ Consider brown field sites listed with the Environmental Protection Agency.
- ✓ Talk with local planning officials to check on Land Bank Authority and incentives available for inner city development (e.g., Empowerment/Enterprise Zones).
- ✓ Consider retrofit and reuse of existing buildings in the urban core.



Photos courtesy of Pimsler Hoss Architects

*Pimsler Hoss Architects were awarded an Urban Design Commission Award of Excellence for Adaptive Reuse by the City of Atlanta for this conversion of an abandoned meat processing facility into 29 apartments of the Swift Company Lofts.*



Courtesy of Macauley Properties

*Ridenour, in Cobb County, Georgia, features a mix of homes, apartments, shops, and offices surrounding a town square. The 88-acre property, being developed by Macauley Properties, will contain a 24-acre historic nature park, an assisted-living center, and a day-care center.*

## Practice 5

# Create Sustainable, Master-Planned Communities

### Why this practice is important

Local governments will probably take years to enact major land use planning changes. In the meantime, “business as usual” solutions will continue to consume open space, harm wildlife habitat, and degrade quality of life. Creative developers have an opportunity to show leadership by incorporating liveable community features into their current plans.

### The solution and its benefits

Today, developers have exciting new planning options to choose from when creating their own

communities. Many master-planned communities are incorporating an array of New Urbanist principles into their designs. Examples of these new urban communities include

- Blount Springs, Birmingham, Alabama
- Legacy Park, Atlanta, Georgia
- New Manchester, Douglas County, Georgia
- Seaside, Florida
- Celebration, Florida
- Harbor Place, Memphis, Tennessee
- Kentlands, Gaithersburg, Maryland
- Mount Laurel, Alabama

These planned communities are setting new standards for more compact, pedestrian-oriented development. Selling points for these communities include the friendly feel of the neighborhoods and the passive recreation opportunities that abound in the shared open spaces. Less emphasis is placed on private yards and golf courses. The new planned communities can greatly reduce the environmental impact of development on the land.

Benefits include

- Tangible models of pedestrian-friendly communities
- Increased opportunities for transit linkage
- Reduced infrastructure cost to local governments
- Increased potential for mixed-income development
- A more stable tax base

### Here's What You Can Do

- ✓ Market environmentally sustainable aspects of a development, including energy efficiency and rainwater harvesting.
- ✓ Feature walking trails and open space that preserves natural features.
- ✓ Create community features such as community-supported agriculture and town squares.
- ✓ Connect neighborhoods to local schools and shopping with walking and bike trails.
- ✓ Plan for ride-sharing and transit options by including facilities that provide safe, pleasant access to transit or other nonautomobile transportation.
- ✓ Work with local government and citizen groups to create improved opportunities for links between developments that do not rely on automobiles.

## Practice 6

# Develop a Smart Growth Plan for Your Community

## Why this practice is important

The interactions of zoning, development, transportation, public facilities, taxation, and utility infrastructure that shape our communities and our lives are complex. Without a community plan to direct growth and develop sustainably, environmental and economic systems will suffer. In contrast, smart growth planning enables communities to plan for growth that enhances their economic, environmental, and social well-being.

## The solution and its benefits

More and more communities across America are seizing opportunities to plan for their future. One interesting method that has been developed jointly by the Washington, Oregon, and California State Energy Offices is called **PL**anning for **Co**munity **E**nergy, **E**conomic, and **E**nvironmental **S**ustainability or **PLACE<sup>3</sup>S**. Using energy and pollution as the measuring sticks, this highly comprehensive modeling system allows communities to see what differences are made by more versus less compact development, or by changing the mix of housing, jobs, and retail development.

Benefits of smart growth planning include

- Increased community awareness and consensus about solutions to sprawl
- Comparison of infrastructure cost, energy use, and pollution for different development types
- Recognition of the regional value of forests, agricultural lands, and open space
- Opportunities to effectively promote pedestrian and bicycle options to local government

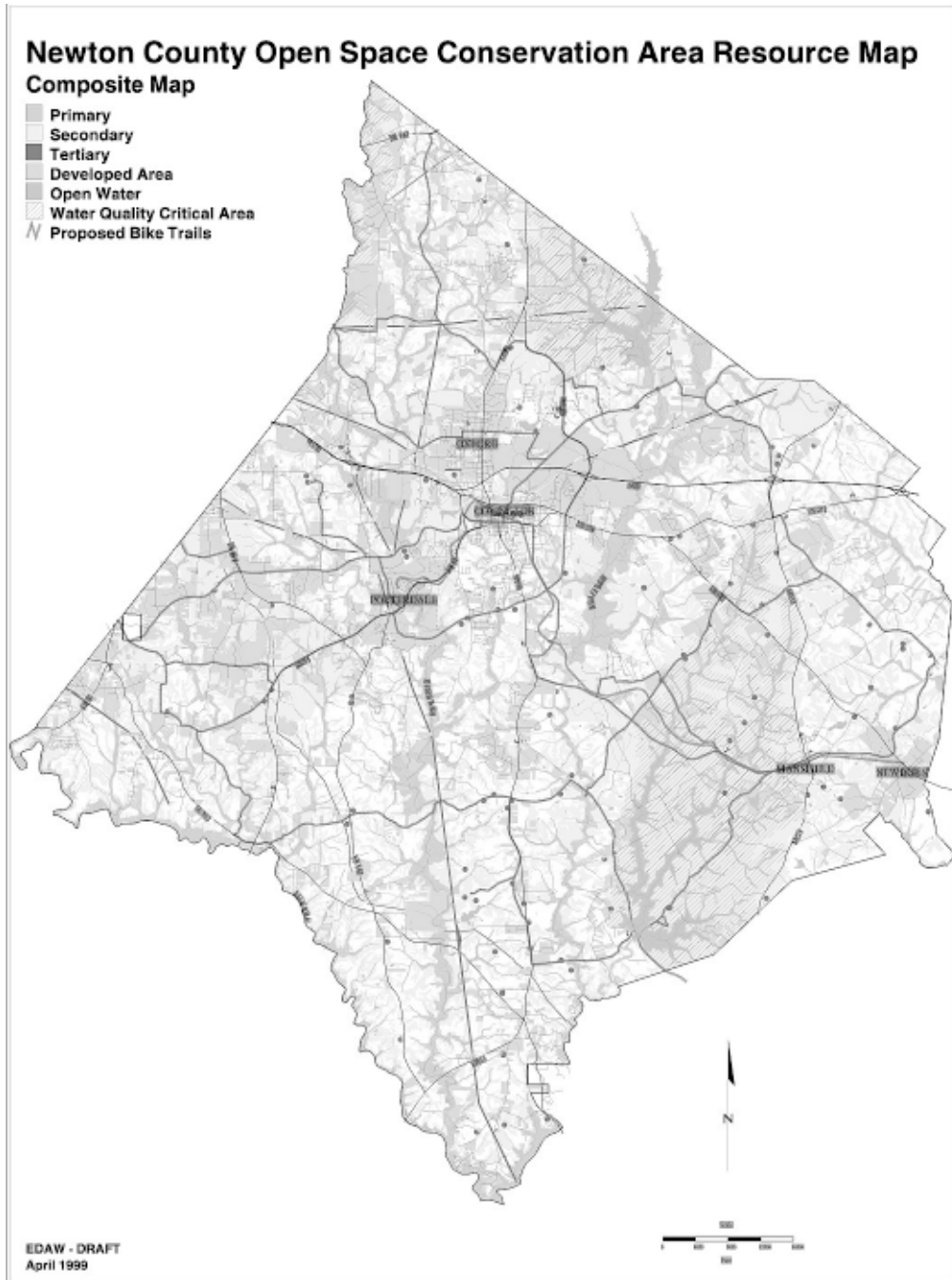

Courtesy of EDAW

*Newton County, Georgia, used mapping of developed areas, natural resources, environmentally sensitive lands, hazardous areas, and historical resources as part of its smart growth plan. Conservation areas are designated primary, secondary, or tertiary depending on their environmental fragility or resource value.*

## Here's What You Can Do

Development and environmental protection need not be mutually exclusive. Making them work together, however, requires a degree of smart planning and regional thinking. The challenge is to employ the market and the community building process to redevelop inner cities and aging suburbs and to preserve natural and open spaces throughout the region.

- ✓ Participate in comprehensive planning efforts in your region and community.
- ✓ Define sustainability indicators for your region.
- ✓ Support a visual preference survey for your community.
- ✓ Seek to develop projects in communities where land preservation and more compact, in-fill development are encouraged by planning laws and guidelines.

## Smart Growth Principles for Minnesota

*The organization 1,000 Friends of Minnesota has developed the following principles for smart growth:*

- 1. Make efficient and effective use of land resources and existing infrastructure by encouraging development in areas with existing infrastructure or capacity to avoid costly duplication of services and costly use of land.*
- 2. Provide a mix of land uses to create a mix of housing choices and opportunities.*
- 3. Make development decisions predictable, fair, and cost-effective.*
- 4. Provide a variety of transportation choices, including pedestrian-friendly neighborhoods.*
- 5. Maintain a unique sense of place by respecting local cultural and natural environmental features.*
- 6. Conserve open space and farmland and preserve critical environmental areas.*
- 7. Encourage stakeholder collaboration and community participation rather than conflict.*
- 8. Provide staged and managed growth in urban transition areas with compact development patterns.*
- 9. Enhance access to equitable public and private resources for everyone.*
- 10. Promote the safety, livability and revitalization of existing urban and rural community centers.*

(Minnesota Smart Growth Network, *Principles for Smart Growth*, March 27, 2000, [http://1000fom.org/Smart\\_Growth/smart\\_growth.html](http://1000fom.org/Smart_Growth/smart_growth.html), accessed June 30, 2000.)

## CHAPTER TWO

# Sustainable Site Development

---

### Introduction

Homebuyers care about sustainable land development. They are concerned about breathing dirty air and drinking dirty water. Threatened loss of streams, trees, and farmland often galvanizes citizen groups into action, while developments featuring protected open space calm opposition and command premium prices. In fact, a focus group sponsored by the Greater Atlanta Home Builders Association found that homebuyers today are more likely than ever to incorporate environmental concerns into their home purchase decisions.

Addressing these concerns and interests offers builders an opportunity to attract new, often upscale business. In addition, adopting sustainable building practices now will help builders stay out in front of a potentially more heavily regulated development environment in the future.



Southface photo

---

*In the 13-county Atlanta region, more than 50,000 new homes were permitted in 1998 at a standard gross density of three units per acre using more than 15,000 acres. If this same number of houses had been built at a gross density of eight units per acre, more than 10,000 acres of land could have been reserved or saved.*

---

## A Summary of Sustainable Site Development Practices

- ✓ Create subdivisions that preserve open space
- ✓ Survey and consider the environmental features of your site
- ✓ Minimize soil disturbance and compaction during construction
- ✓ Control erosion and sedimentation during construction
- ✓ Protect trees during site clearing and construction
- ✓ Use landscaping for energy and water efficiency
- ✓ Manage stormwater naturally
- ✓ Reduce irrigation needs by harvesting water on site
- ✓ Promote environmental awareness and stewardship

## Practice 1

---

### Create Subdivisions That Preserve Open Space

---

#### Why this practice is important

Conventional subdivision developments divide the entire site into individually maintained yards that can fracture wildlife habitat and increase pollutant loading into streams and groundwater. In addition, many fast-growing rural areas have moved toward large-lot zoning, creating a development pattern that promises sprawling “farmettes.” While very-low-density strategies (2 to 5 acres per unit) can provide short-term relief from sprawl, the long-term result is often fragmented habitats, eventual pressure to “in-fill” anyway, and guaranteed dependence on the automobile.

#### The solution and its benefits

An alternative to conventional development is an offsetting density strategy, which enables developers to limit development to less environmentally sensitive portions of the site in exchange for increased density on the built-out sites. Lot sizes from 10,000 to 20,000 square feet ( $\frac{1}{4}$  to  $\frac{1}{2}$  acre) yield two to three buildable units per acre. Thus, a 40-acre subdivision could yield up to 120 homes. If the average lot size is decreased to 3,200 square feet (40 x 80 feet), the yield per acre increases to around eight units per acre. With the higher-density development, and with the total yield for the site limited to 120 homes, 25 acres of the 40-acre site are preserved. Developments that use this strategy are called conservation subdivisions.





Courtesy of East Lake Commons, Inc. and Village Habitat

*The East Lake Commons development demonstrates the principles of employing offsetting density to preserve open space. Zoned for 72 units on 18 acres in southeast Atlanta, Village Habitat created a design for a conservation subdivision that has preserved nearly 10 acres, or half the land, as gardens, stream buffer, and even a small woodland area. The major goals for East Lake Commons included*

- *Preserved open spaces (w woodland and agriculture areas and the development commons)*
- *Pedestrian-friendly spaces*
- *Shared security*
- *Reduced paving and control of stormwater runoff*
- *Protection of streams and wooded areas*
- *A broad range of home prices*
- *Connections and buffers to the adjacent neighborhood*
- *Solar orientation and energy-efficient construction*

*In addition, there were several homeowner goals:*

- *Community educational opportunities*
- *Home-based business and telecommuting opportunities*
- *Shared community resources*
- *Community-supported agriculture opportunities*

The major advantages for both the developer and the homebuyer include

- Reduction in infrastructure costs
- Increased access to pocket parks and larger open spaces
- Improved sense of community and shared security
- Reduced cost of maintaining private yards
- Improved marketability of homes
- Tax benefits from conservation easements

For the jurisdiction and larger community, advantages include

- Reduction in street and infrastructure maintenance costs
- Reduction in stormwater impacts and improved watershed protection
- Improvements in biodiversity and natural cooling affects
- Contribution to overall community open space goals

The overall development goal of a jurisdiction will influence the amount of land that should be set aside for each offsetting density or open space plan. While the amount of preserved land should be higher the farther the development is from the preferred development corridors and existing transportation infrastructure, the density for the built-out portion of the property should remain relatively high.

Dollar, energy, and pollution savings per family are possible when a 12 unit per acre development replaces a 3 unit per acre one:

- Approximately 50% reduction in infrastructure costs per family—\$27,500 instead of \$42,500 for streets, utilities, and schools
- Up to 10% reduction in total energy costs per household including reduced vehicle trip miles, or about \$500 per year per family
- Up to 3 fewer tons of carbon dioxide emissions per family annually

## Here's What You Can Do

- ✓ Use an offsetting density approach to create a conservation subdivision or similar open space development.

According to Randall Arendt, author of *Conservation Design for Subdivisions*, the central organizing principle of a conservation subdivision is sensitive preservation of at least half the original open space, in addition to land typically already set aside.

The four basic steps in creating a conservation subdivision are as follows:

### *Step One: Identifying Conservation Areas*

The first step consists of identifying primary conservation areas that are already excluded from development due to regulations (i.e., wetlands, steep slopes, floodplains), and then secondary conservation areas containing other open space worthy of protection from clearing, grading, and development (i.e., mature woodlands, wildlife habitats, prime farmland, scenic areas, and historic buildings).

### *Step Two: Locating House Sites*

The second step involves identifying the approximate sites of houses, which are strategically placed to maximize enjoyment of the conservation areas. In a full-density plan, the number of house sites will be equal to that permitted under the relevant zoning. Reducing density to create a “limited development” plan is also an option, which in an upscale development might produce the same economic benefit for the landowner.

### *Step Three: Aligning Streets and Trails*

The third step consists of a logical alignment for local streets and informal footpaths to connect various parts of the neighborhood, with special attention to creating opportunities for passive recreation and for neighbors to socialize.

#### *Step Four: Drawing in the Lot Lines*

The final step is to draw in the lot lines with an understanding that most buyers prefer homes in attractive parklike settings and that views of protected open spaces will ensure faster sales at premium prices.

- ✓ Work to improve zoning that allows for open space.

While the concept of a conservation subdivision may appeal to many developers, many current zoning codes may prohibit it. It is important to gain community understanding of the goals of open space preservation. A change in the zoning to what some call “open space zoning” may be required.

- ✓ Create incentives for developers to preserve more green space.

Encourage changes to zoning regulations that can create incentives for open space preservation. Incentives can include

- Streamlined zoning and permitting review process
- Allowance for an increase in density
- Reduced impact or other “hook-up” fees
- Tax benefits

---

#### **Master-Planned Conservation Developments**

*An excellent resource for creating large communities of between 3,000 and 10,000 housing units is Reid Ewing’s book Best Development Practices. In this well-documented handbook, Ewing clearly divides his subject matter into a series of best practices for land use, transportation, environment, and housing. The book describes several new communities in Florida, including Bluewater Bay and Hunter’s Creek, that incorporate environmentally sustainable design features, including*

- Significant amounts of natural land permanently protected
  - Bio-swales and other stormwater infiltration techniques
  - Constructed wetlands for purification of stormwater
  - Pedestrian and bike friendly trails and facilities
  - Shared recreational facilities and neighborhood commercial districts
-

## Survey and Consider the Environmental Features of Your Site

### Why this practice is important

Through either a lack of education or recognized financial incentives, most housing developments today result in a severe loss of wildlife habitat, agricultural land, and open space that could otherwise help maintain biodiversity and be enjoyed by people.

### The solution and its benefits

To maximize the goal of preserving sensitive habitat while building on more suitable portions of the site, developers must first know what should be left undisturbed and permanently protected. To “do the least harm,” developers should begin by knowing the land intimately. The physical characteristics of the land can then guide buildings placement within the site.

Benefits include

- Protection of watersheds
- Preservation of wildlife
- Reduced tree loss
- Preservation of cultural resources
- Preservation of agricultural land
- Increased lot values
- Reduced energy use in buildings

Each of the following site elements should be carefully considered and mapped to cause the least environmental harm and create the greenest possible development:

#### ✓ Topography

A topographical survey will reveal those areas that are either too steep or too flat to become the best sites. Slopes in excess of 30% are difficult to develop, and even a 15% slope is undesirable for soil types that erode easily. Some flat areas of the site may also best be designated for gardens, parking, and passive recreation. A field surveyor can perform an accurate survey of the site. Money can be saved by not surveying those areas that are obviously inappropriate for development.

#### ✓ Solar orientation

Proper solar orientation can make a significant difference in the energy efficiency of buildings. Orienting homes so that the longest side is facing south can provide an opportunity for passive solar heating during winter.

#### ✓ Soil

Basic knowledge of soil conditions is essential when considering location of septic systems, the degree to which stormwater will infiltrate, and the bearing and freeze/thaw characteristics for footings. Local permitting bureaus and health departments generally require evidence of soil conditions before approving a site plan and septic systems.

#### ✓ Hydrology

Developing a site map with surface water and wetland features is critical to the site planning process. In addition, hydrological studies including annual rainfall amounts and peak flow rates may be required to determine how the total area of planned impervious surfaces will affect stormwater management. Recent depth and water



Courtesy of Macauley Properties

*Developer Stephen Macauley has created a unique development north of Atlanta called Legacy Park. Macauley preserved significant amounts of open space, protecting a stream corridor and providing acres of natural area for passive recreation and wildlife habitat. These elements enhance the development and are being marketed successfully. Lots adjacent to the preserved open spaces fetch a significant premium over others.*

recharge rate data for local wells can provide good information about the viability of wells on site.

☑ **Trees and vegetation**

A tree and vegetation survey of a site are key components of site assessment. Large trees are difficult to replace and add considerable aesthetic, sales, and cooling value to a development. Some areas of the site may contain concentrations of undisturbed native species worthy of preservation. Arborists and other professionals can be contracted to survey the types, sizes, and health of trees and other vegetation. It is up to the developer to decide the level of detail an arborist is asked to capture. In some cases, local tree ordinances require a tree survey followed by a plan for tree protection and replacement.

☑ **Wildlife habitats**

Evaluation of wildlife habitats should be done as part of the survey of native vegetation and wetlands. Habitat fragmentation is one of the most significant contributors to the rapid extinction of plant and animal species and loss of biodiversity. Maintaining healthy greenways and buffers through subdivisions and especially along creek and river banks is the key to both protecting and enhancing wildlife populations.

☑ **Historical/ cultural artifacts**

Most parts of the country have seen previous human habitation. There may be opportunities to preserve elements of the past. Stone walls, chimneys, and even abandoned gravesites can be incorporated into a preservation plan and enhance the interest and marketability of a development.

## Practice 3

# Minimize Soil Disturbance and Compaction during Construction

### Why this practice is important

Disturbing healthy soil contributes to greater erosion and risks damage to sensitive tree and other plant root systems. In addition, overly compacted soil prevents adequate absorption of water and nutrients, causing stress to both established and newly planted landscape materials.

### The solution and its benefits

Taking preventive measures in advance of construction greatly reduces erosion and increases the survival rate of trees and landscape plantings. Erosion control actions can be included in the demolition, grading, and foundation/basement excavation plans.

## Here's What You Can Do

The following steps should be included in plans prior to start of clearing, grubbing, and other site preparation activities:

- ✓ Carefully plan grading activities to minimize “borrow and fill” and to minimize creation of artificial slopes greater than 30%.
- ✓ Phase grading into manageable sections of the site to minimize the amount of time earth is exposed to wind and rain.
- ✓ Clearly establish site access and staging areas at portions of the property where soil disturbance will occur for building sites, drives, and parking. Avoid areas planned to be left natural or overseeded.
- ✓ Fence and isolate hazardous material storage areas to prevent contamination and to encourage organized removal of hazardous wastes to appropriate disposal sites.
- ✓ Minimize the number of roads into the site, limit stream crossing, and locate roads across the slope, not up and down.
- ✓ Avoid filling sections of the site that function as drainage or water recharge areas.
- ✓ Use appropriately sized grading equipment to minimize the weight placed on sensitive soils, especially when it is necessary to work close to mature trees.
- ✓ Save excavated topsoil and protect it from rain and wind with tarps for later use.
- ✓ Place all mineral soils that will be used for back fill in a separate location and protect them from rain and wind with tarps.
- ✓ Carefully specify control measures in contracts and establish penalties for failure to adequately protect specified areas of the site.

## Practice 4

# Control Erosion and Sedimentation during Construction

### Why this practice is important

As development occurs, streams receive increased sediment from construction sites and other disturbed areas. Even after development, sediment levels seldom return to predevelopment levels because of streambank erosion. Sediment degrades streams and damages the natural habitat. Streambeds are scoured or covered with silt; plant life is destroyed; and fish and aquatic insect eggs are smothered. Sediment can block drainage pipes and fill channels, increasing the risk of flooding. In reservoirs and lakes, sediment can block water supply intakes, reducing the amount of water stored and the quality of water available, as well as increasing maintenance and treatment costs.

### The solution and its benefits

As a result of recent focus on erosion and sediment control, permitting bureaus now require detailed erosion and sedimentation control plans for most developments and issue stop work orders and fines for failure to comply.

Fortunately, many new best management practices introduced in recent years provide developers with reasonably priced options to control erosion on their construction sites.

---

*A high sedimentation level is one reason the nonprofit group American Rivers listed the Chattahoochee River in Georgia as the seventh most endangered river in America in 1998.*

---

## Here's What You Can Do

The following steps will help alleviate erosion on disturbed areas of the site:

- ✓ Limit the amount of soil disturbance on the site.
- ✓ Clearly indicate on plans which areas of the site will be graded, identify erosion control measures, and indicate on plans where these measures are to be installed.
- ✓ Install temporary silt fencing in line with site contours so that not more than  $\frac{1}{4}$  acre is protected for each 100 lineal feet of fencing. On steep slopes and during rainy seasons doubling and reinforcing silt fencing may be required to do the job.
- ✓ Use temporary sedimentation catchers, or silt ponds, to catch and trap bulk sediment during construction.
- ✓ Immediately after grading, install temporary slope stabilization measures, including blown straw with binder and hydro-seeding with fast-growing temporary grass.
- ✓ Create appropriate protection for drain inlets, including concrete blocks covered with erosion-control material oriented to allow water through while filtering out sediment. The entire assembly must be surrounded with gravel.

## Soil and Sedimentation Regulations Getting Tougher

Several factors have combined to make regulators more aware of erosion and sedimentation issues. Some regional water boards such as the one in Birmingham, Alabama, have seen a rapid rise in water intake equipment problems resulting from excessive sedimentation levels. As a result of growing awareness of construction site runoff, the EPA established regulatory guidelines in 1990 that require soil and sedimentation control on sites that are 5 acres or larger. Regulations tightened in 2000 to include sites as small as 1 acre. In addition, the new water quality standards set by the reauthorized Clean Water Act of 1992 have focused the attention of state and local regulators on the issue of erosion control, with resulting measures such as the Georgia Erosion and Sedimentation Act.

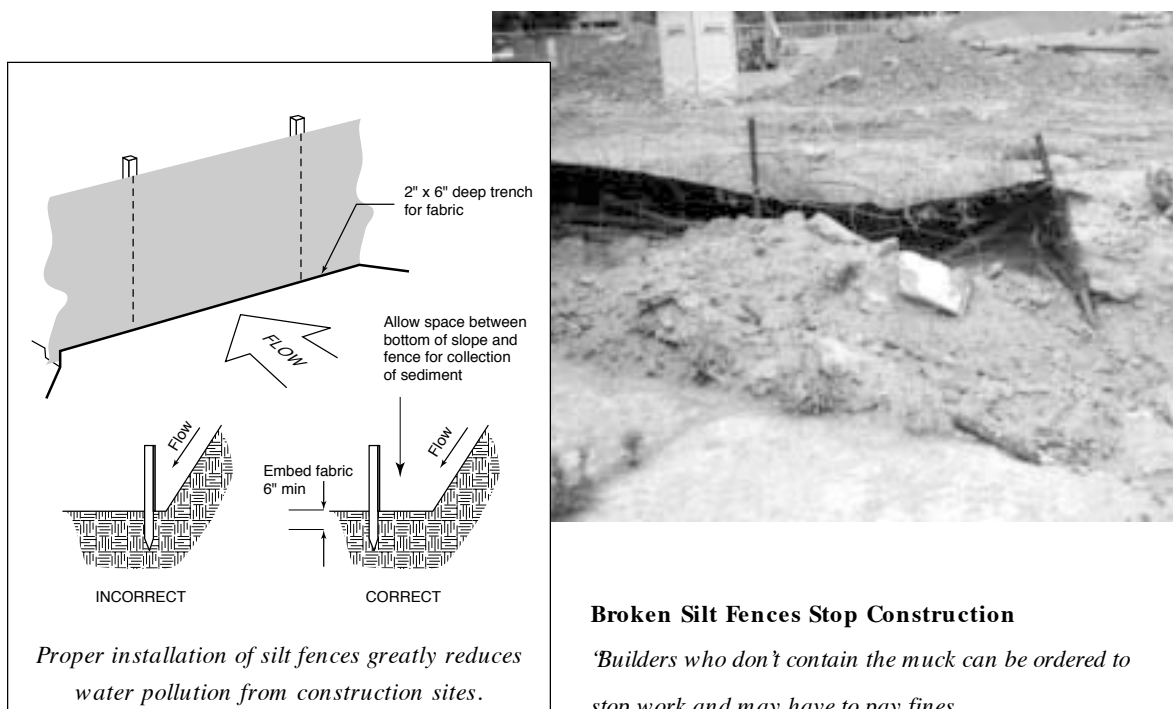

### Broken Silt Fences Stop Construction

*'Builders who don't contain the muck can be ordered to stop work and may have to pay fines.*

*'Recent hard rains have made hard times for builders, as several communities all over metro Atlanta have ordered construction stopped at sites where erosion washed red dirt into streams, and onto people's property. . . . In the past two weeks, Alpharetta officials stopped work at about 50 construction sites, which represents about a quarter of all construction sites in the city. . . . Meanwhile, Fulton County also has shut down about 20 sites in the past two weeks. We've adopted a zero tolerance attitude in the past six months,' said John Robinson, deputy director of the department of environment and community development.'*

(Craig, Schneider, "Broken Silt Fences Stop Construction," *Atlanta Journal/ Constitution*, March 19, 1998.)



## Practice 5

# Protect Trees during Site Clearing and Construction

### Why this practice is important

The public is often concerned about new housing developments. A 1998 focus group study conducted by the Greater Atlanta Home Builders Association found that many respondents “perceived that builders were primarily, if not solely, responsible for clear-cutting trees during land development.” Sprawl style developments, with enormous amounts of land area cleared for roads, parking areas, and low-density commercial development, are responsible for a major percentage of tree loss and permanent coverage of soils.

Those trees not cut typically receive three main types of damage during construction: physical, chemical, and hydrological.

Physical damage to roots occurs most often from grading, excavation, and trenching. Roots can also suffocate from compaction of the soil by foot and vehicular traffic, or by adding soil over the top of the root system, especially in areas with clay soils. Physical damage to foliage can also occur if large trees or major limbs are removed, leaving more delicate understory trees to suffer sun scalding, wind, and storm damage.

Spilled paints, thinners, cement, muriatic acid, fuel, and other fluids can cause chemical damage during construction. Spills can cause long-lasting changes in the soil or be directly toxic to roots.

Hydrological damage to trees is caused by altering established patterns of water drainage or flow. Normal water sources can be cut off by grade changes and barriers such as drives and walks, leading to possible drought stress. Just as much

Tunneling  
under roots

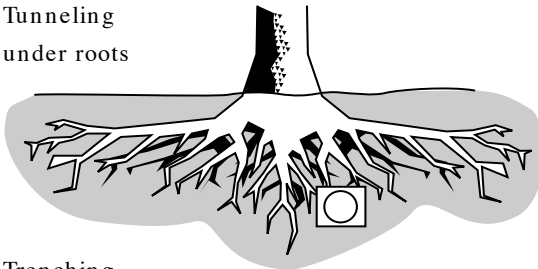

Trenching  
through roots

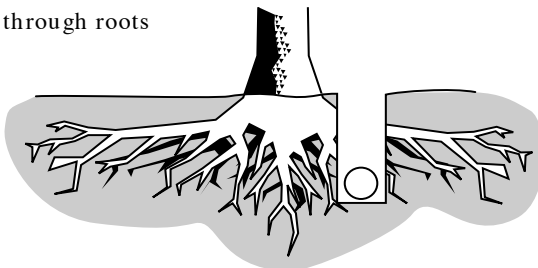

Utility installation on the construction site can damage tree roots. Tunneling under root systems is preferred, rather than trenching through root zones, which can damage or kill trees.

### The Importance of Roots

*The most important rule to follow in saving trees is to protect the root system. Utility trenching near a tree can remove 40% of a tree's root system, practically guaranteeing death. Roots serve three main functions for trees:*

- *Physical support to anchor the tree in the soil*
- *Water uptake for the entire tree*
- *Nutrient extraction from the soil*

*Damage to the root system interferes with any or all of these functions and leads to problems that may not be obvious for years. Root systems typically extend well beyond the dripline of the branches. Nearly all of the roots are in the top two feet of soil; more than half are in the top one foot.*

damage can be done by redirecting excessive amounts of water into trees areas, resulting in saturated soils and root suffocation.

## The solution and its benefits

Mature trees not only shade homes; they also help absorb excess stormwater. A mature forest, for example, can significantly increase the water-holding capacity of soil because of the depth of roots. Shallow-rooted plants typically have about a fourth of the water-holding capacity of mature forest cover.

---

### Cool Communities

*Cool Communities is an action-oriented energy-reduction program of the nonprofit group American Forests.*

*Cooperative federal support is provided by the EPA, the Department of Energy (DOE), the Forest Service, the Department of Defense, and other agencies. Cool Communities mobilizes government agencies, businesses, and citizens to create positive, measurable change in energy consumption and the urban environment through strategic tree planting and light-colored surfacing, and to increase public awareness of these issues.*

*In 1992, seven model communities of various climates and sizes were selected to initiate the program. Using information from the EPA's guidebook, Cooling Our Communities, and American Forests' tree-planting handbook, Growing Greener Cities, local advisory groups in each community have been reducing energy use, planting trees, lightening surfaces, and providing examples for other communities to develop similar environmental improvement campaigns.*

*American Forest research has revealed the following information:*

- *In metropolitan Atlanta, Georgia, vegetation provides more than \$1 billion in stormwater management benefits.*
- *By reducing airborne carbon, trees provide a value of \$9.2 million in Austin, Texas.*
- *In Dade County, Florida, \$14.4 million in energy savings could be achieved by planting just one tree at each residence.*

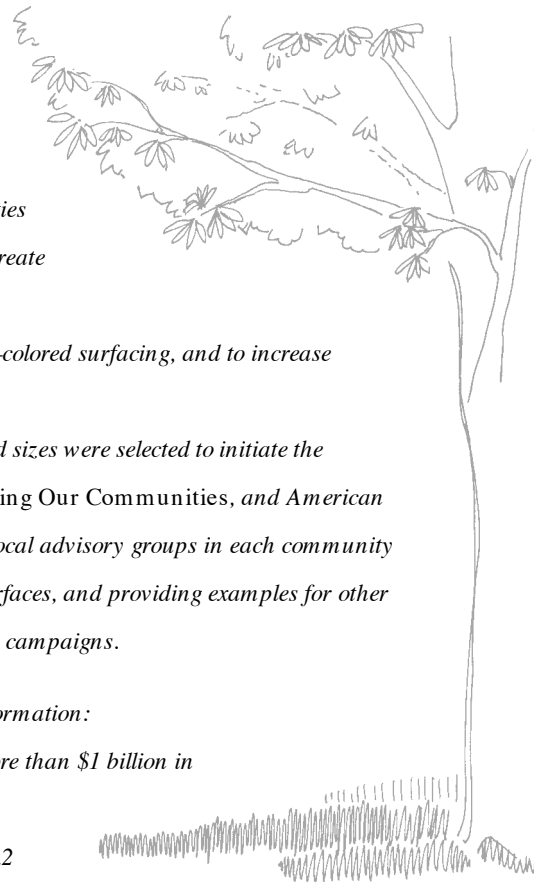

## Here's What You Can Do

- ✓ Develop and implement a “tree save” plan.
- Carefully identify the species and size (caliper) of all trees that will remain after construction. Prior to construction, prune unhealthy branches and those that will need to be removed for construction purposes.
- Create a tree protection plan and indicate “tree save” areas. Each tree save area should be as large as possible, but at minimum retain a radius of 2 feet for each inch of trunk diameter. So a 10-inch-diameter tree will have a 20-foot-radius tree save area around it. If groups of trees are saved, the outer perimeter of the tree save area should be as large as possible.
- Clearly indicate the types of barricades that will be used on site. For especially significant trees that are close to grading and construction areas, consider specifying temporary cyclone fencing to ensure avoidance.
- Place penalties and incentive clauses in contracts to encourage contractor and worker involvement in tree protection.
- Inspect the tree save areas prior to start of grading or construction. Every worker on site must be aware of the importance of the trees to the owner.
- Mulch tree save areas and fertilize with appropriate amounts of phosphorus and potassium. Water regularly during construction. If an area that will suffer root damage is identified in advance, root pruning and fertilization should occur several months ahead of time to encourage compensating root growth prior to construction.
- Reroute utility trenches around tree save areas. If rerouting is not possible, bore holes through tree root areas rather than trenching (see the sidebar on page 31).

- Where grade levels will be changed near trees, specify retaining walls and tree wells, preferably located at the same distance from the trunk as the tree-protection barrier (2 feet per inch of trunk diameter).
- Avoid storing or using chemicals within tree save areas.
- Avoid changes to stormwater routing that will either add to or subtract from normal water flows to the tree save areas.
- Avoid exposing understory trees whenever possible or do so only when trees are dormant.

### ✓ Transplant trees.

In some cases, transplanting small trees makes sense. Here are a few tips to follow:

- Trees up to 2 to 3 inches in diameter can generally be dug by hand.
- Trees up to 10 to 12 inches must be dug with a commercial tree spade.
- If possible, replant trees immediately, feeding, watering, mulching, and staking to provide support. If trees cannot be replanted immediately, create a holding area where they can be “healed in” in soil or mulch (compost or small bark is better than straw) and watered frequently. Partial shade helps reduce wilting.

Since up to 90% of the tree’s feeder root system is lost during transplanting, it is always best to move trees when they are dormant in winter. The greatest root growth in trees is stimulated by a hormone secreted as leaf buds begin to swell in early spring. Digging afterwards may result in the tree not regrowing roots as vigorously.

## Practice 6

# Use Landscaping for Energy and Water Efficiency

### Why this practice is important

In an effort to reduce housing costs, builders often do not consider the long-term benefits of carefully placed yard trees and other environmentally beneficial landscaping. In some cases, thoughtful homebuyers do plant trees after they move in. Unfortunately, most simply never get around to changing or improving the original landscape “package” provided by the builder. Hot, barren yards often stay that way and create long-term energy, comfort, and resale penalties.

#### *Heat island effect*

In developed areas, the lack or loss of trees contributes to the heat island effect: the difference in temperature from rural to built-up

areas. The rural-urban temperature difference ranges from as little as 2°F for St. Louis, Missouri, to 10°F for New York City. Peak utility cooling demand increases 1.5 to 2% for every 1°F increase in temperature. The heat island effect exacerbates problems for communities across the South that are experiencing new peak demand levels for electric air conditioning in summer.

#### *Increased ground-level ozone (smog)*

Increasing temperatures in the summer elevate pollution because hotter temperatures speed the chemical reactions that lead to ozone formation. The ozone increase leads to increased respiratory illness. A recent Centers for Disease Control study indicated that in Atlanta, Georgia, emergency room admissions can increase by a third on high ozone alert days because of asthma and other respiratory conditions.

#### *Wasted and polluted water*

Poorly planned landscaping also results in yards filled with high maintenance vegetation that requires extensive watering, as well as costly fertilizers, herbicides, and pesticides. Every year, Americans spend more than \$25 billion

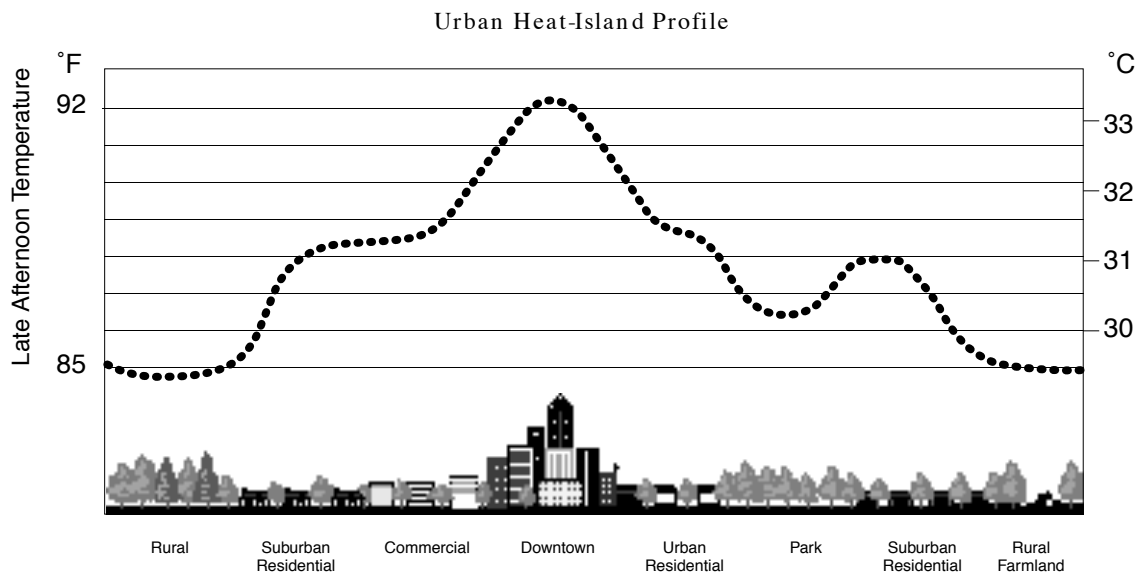

This sketch of a hypothetical urban heat island profile shows that urban areas are typically 2° to 8°F higher than surrounding rural areas in summer.

maintaining nearly 50,000 square miles of lawn — an area the size of the state of New York. Runoff from the nearly 6 million tons of fertilizer, as well as 34,000 tons of herbicides, insecticides, fungicides, and various other pesticides degrades streams, wildlife habitats, and groundwater.

### The solution and its benefits

Proper selection and placement of native plant materials can greatly reduce the need for water, chemicals, and maintenance labor. Significant savings over time will result from a yard plan that may cost a bit more on the front end but pays long-term benefits to homeowners and the environment. Together with shade trees, this ecological approach to landscape design and installation can be marketed by builders and realtors as a valuable feature of the home.

#### *Landscaping adds value to homes*

Trees especially provide substantial value to homes and subdivisions. The National Association of Home Builders and American Forests have found that mature trees can add from \$3,000 to \$15,000 to the value of a residential lot. In a survey conducted by Bank America Mortgage, 84% of realtors felt that a home with trees would be as much as 20% more salable than a home without trees. A single well-placed mature tree can provide significant reductions in cooling costs.

#### *Trees reduce summer cooling and winter heating costs*

Well-placed trees can save homeowners from 15 to 50% on summer cooling costs. The higher the number of cooling days and the lower the levels of insulation, the higher the savings. Even though winter wind speeds for most of the Southeast are modest, trees, shrubs, or landscaping fencing can buffer prevailing winter winds with some heating cost reductions.

---

### The Heat Island Effect in a Parking Lot

*NASA has been documenting the heat island effect for a number of years. For example, heat-sensitive photographs of a shopping mall in Huntsville, Alabama, show that the mall and other buildings, parking lots, and roads are very warm during the day, and the parking lot is still “glowing” at night. By contrast, wooded areas and even small tree islands in the parking lot appear as cool spots. The difference has to do with how materials absorb and release heat. Asphalt absorbs heat from the sun and quickly releases it as heat radiation. Temperatures in the parking lot in the summer of 1994 were as high as 120°F during the day, while tree islands in the lot were 89°F—a difference of 31°! Nearby wooded areas were another 4°F lower than the parking lot tree islands, at 85°F.*

---

### Here's What You Can Do

- ✓ Select and locate trees appropriately.
  - To permit winter sunlight to heat the home and provide natural light, minimize trees on the south side of the home—even deciduous tree branches block the sun.
  - On the southeast, southwest, east, and west sides of the home, plant deciduous trees that will grow large with spreading crowns and dense foliage for shading.
  - Choose the largest trees your budget will allow (1- to 3-inch caliper), and select species that are best suited for your region, preferably native varieties.

- Avoid cutting trees to capture solar gain — the \$30 or so saved annually on heating costs will not equal the value of the tree.

- ✓ Use other landscaping to increase benefits.

In addition to using trees for cooling, use of ground covers, shrubs, and trellises covered with vines can greatly reduce air temperatures near a home. Avoid dense foliage plantings within the drip line of southern homes because of foundation humidity concerns. Choose water-conserving native species whenever possible.

- ✓ Use regionally appropriate landscaping materials.

Imitate local plant ecosystems, rather than relying on exotic species, to help maximize the survival of landscaping materials. Clay soils, for example, compact easily and often require significant conditioning and soil amendments to be productive. Plants that are well adapted to the local soil and moisture conditions require lower levels of water, fertilizers, and maintenance; and their use reduces the risk of plant disease.

---

### Rethinking the American Lawn

*The United States pumps an average of 82 billion gallons of groundwater every day, while the daily recharge rate is only 61 billion gallons. In some urban areas of the South, 40 to 60% of the water supply is used for landscape watering. During summer months, landscape watering can easily account for up to 80% of water use. Use of local plants can minimize the need for landscape watering.*

*For example, the most recognized species of turf grass, Kentucky bluegrass, is not actually native to the United States (despite its name) and requires 35 to 40 inches of water per year. It is widely grown in areas that receive less than half that amount in rainfall.*

*The EPA has calculated that the use of native prairie grasses in the Midwest as opposed to Kentucky bluegrass can save as much as \$4,690 per year per acre in watering and chemical inputs. While turf coverage can help prevent soil erosion and does contribute to water infiltration and cleaner air, other solutions are available that do even more and have no environmental downsides. A goal should be to reduce the need for water by as much as 80%. The amount of chemicals saved usually equals the reduction in water usage.*



- ✓ Utilize the principles of xeriscaping.

Xeriscaping, when properly implemented, is a cost-effective method of landscaping to conserve water and other resources on a residential and community-wide level.

Xeriscaping's basic principles:

- Understand your area climate and the micro-climate of your site.
- Test your soils.
- Plan “water-use zones,” creating areas of low, moderate, and high water demand. Maximize low-water-use areas and minimize moderate-use areas. Save high-demand areas for the most important entryways and specimen plants.
- Select plants that match the water-use zones.
- Restrict turf areas to functional areas such as recreational areas and zones with higher foot traffic.
- Mulch regularly to help prevent evaporation.
- Irrigate wisely using drip or micro-sprinklers. Avoid watering daily (encourages shallow root formation) and water only between 9 P.M. and 9 A.M. to reduce evaporation. Water deeply to encourage deep root growth.
- Avoid trimming shrubs and plants or fertilizing during dry periods to suppress water-demanding new growth.

- ✓ Use landscaping to create habitat for wildlife.

Select trees, shrubs, and flowers that provide food and habitat for wildlife. Many native species of trees and plants are preferred by local or migrating birds and other animals.

## Practice 7

# Manage Stormwater Naturally

## Why this practice is important

Modern suburban development has dramatically increased the amount of impervious surface area throughout the Southeast. Low-density development and the dominance of the automobile results in the paving of a half million acres for roads, parking lots, and driveways each year. A typical subdivision today covers up to 40% of the land with impervious surfaces. Two thirds of this area is devoted to the automobile.

Impervious roofs and pavements prevent natural absorption, storing, and routing of storm water. By deflecting water across the surface, they make floods bigger downstream. Most subdivisions use a combination of pipes and culverts to collect and move water away from the area. This method has the cumulative effect of increasing stream flow, causing downstream erosion, and flushing out aquatic life.

For sites with less than 10% impervious surface area, development typically does little damage to streambeds. Between 10 and 30%, stream health is impacted. At more than 30%, stream health degrades without special measures. The greatest threat to streambed health is high sedimentation levels caused by soil erosion and stream bank deterioration.

In addition to sedimentation, residues from automobile fuels, lubricants, and exhaust that collect on parking lots and roadbeds are dissolved during the initial part of a rain shower, then are washed into streams, causing stress to aquatic life.

## The solution and its benefits

Today, it is possible to design subdivisions and communities that reduce stormwater runoff and even improve the quality of water moving over a site. Builders and homeowners need to think about stormwater as both a valuable resource and a potential pollutant. Allowing water to infiltrate into the ground improves water purity, recharges aquifers, and improves the “base” flows of area streams and rivers, while reducing peak flows, flooding, and pollutant transfer.

### Here's What You Can Do

- ✓ Reduce land area devoted to automobiles.

Most subdivision have roads that are too wide or could be shortened using offsetting density principles or some form of shared parking. In some cases, the developer will need to work with public officials to allow less roadway.

- ✓ Create natural storm water pathways.

Capture stormwater where it runs off of streets and drives and allow it to infiltrate in planted ditches or vegetated swales. Avoid burying streams in pipes or running them through concrete troughs by either maintaining or recreating natural creek beds designed to handle additional flow strengths.

- ✓ Landscape to minimize runoff and promote natural infiltration on home sites.

Landscape to keep stormwater on site as long as possible so that it can be absorbed into the ground. The following design measures can make a big difference:

- Leave as much land as possible on the site undisturbed.
- Ensure that healthy ground cover is established over all disturbed soils.
- Recreate natural areas using hearty native

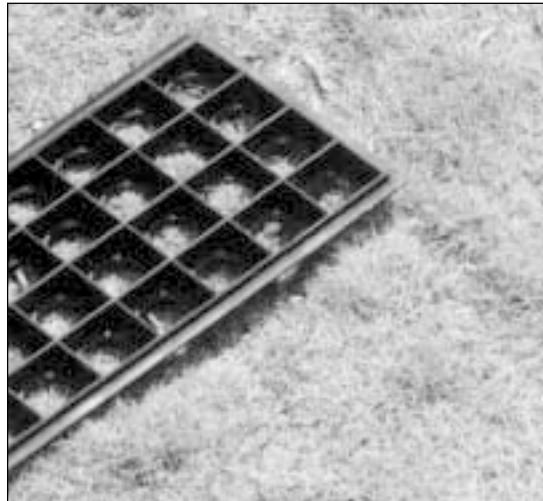

### Grass Parking Lot at Southface Energy and Environmental Resource Center

*Several systems permit the use of grass turf over a plastic or concrete substrate that contains holes for water infiltration and turf root irrigation. The Southface Energy and Environmental Resource Center in Atlanta, Georgia, uses Grasspave2 Porous Paving System. This system consists of an open cell matrix made of 100% post-consumer recycled plastic that is laid over a gravel base and planted with turf grass. Once established, the grass will absorb up to 6 inches of rain over a 24-hour period.*

plantings (the deeper the roots the more water will be absorbed).

- Mulch all trees and shrubs.
- Divert water away from steep slopes and disturbed areas with dikes, swales, and ditches into areas that have established plant materials or other absorbent cover.
- Break long slopes with ditches, swales, and terraces (or checkdams).



- ✓ Use structural systems that encourage infiltration.

Design systems that slow runoff and allow water to infiltrate directly or move to landscaped areas. Consider the following systems:

- No gutters; water is evenly disbursed into gravel “Dutch drains” installed along the drip line allowing water to infiltrate away from foundation
- Gutters with downspouts diverted into water harvesting pools or cisterns
- Gutters with additional downspouts (more may be needed to break up flow volume) that are directed into planted areas or gravel drainage basins
- No curbing along sidewalks and driveways to allow water to flow onto planted zones or infiltration basins
- Porous pavements on driveways and parking pads
- Grass pavers that take auto weight but allow grass to grow
- Infiltration basins that capture excess stormwater from driveways, walks, and less porous areas of the yard
- Subsurface basins installed below parking lots to enable stormwater to be stored and absorbed slowly into surrounding soils



*Porous paved driveway at Southface Energy Institute receives its “smooth” coat.*

- ✓ Build parking lots that absorb water.

A technique that is growing in popularity is the use of porous pavements that allow stormwater to infiltrate directly into parking lots and drives. Porous pavements are made with either concrete or asphalt that is mixed with a small, consistently sized gravel aggregate. Depending on soil types, this strategy will vary in cost and effectiveness. While materials can cost more than for standard concrete, installing porous concrete is faster and may lessen the need for stormwater management infrastructure.

- ✓ Support local government efforts to establish storm water utilities.

In order to more directly meet the costs associated with best stormwater management practices, many local governments need to consider charging property owners for the long-term cost of maintaining a healthy stormwater system. Local governments should also try to establish incentives for better on-site management practices.



Southface photo

*The Carter Presidential Center in Atlanta, Georgia, uses a one-acre stormwater retention pond to collect rain from rooftops and parking lots for landscape irrigation. Not only does the Center keep pollutants and excess stormwater out of the city's sewer system, but it is saving \$50,000 and about 10 million gallons of potable water each year.*

## Practice 8

# Reduce Irrigation Needs by Harvesting Water on Site

### Why this practice is important

Irrigation for yards, gardens, parks, and golf courses consumes large quantities of potable water each year. The practice wastes water that required chemicals and energy to purify and deliver. At the same time, impervious surface areas have dramatically increased stormwater runoff that overloads streams, increases pollution, and decreases groundwater recharge.

### The solution and its benefits

The use of rainwater for irrigation, and even as potable water, is an old idea that has more merit today than ever. Stormwater runoff can become a valuable water resource in many regions of the country. Water that would otherwise run off roofs and landscapes can be captured in many ways and put to productive use. Systems can be developed that serve low-volume needs such as lawns and gardens as well as large municipal parks and golf courses.

In addition, billions of gallons of mildly contaminated water from baths, dishwashers, and washing machines, known as graywater, can be captured for landscape irrigation or other uses.

## Here's What You Can Do

- ✓ Create water reuse ponds.

Stormwater runoff can be captured and stored in a pond, then pumped to irrigate pervious areas such as golf courses, cemeteries, gardens, community open space, and turf.

When water is reapplied to the watershed from a water reuse pond, groundwater recharge takes place and soil organisms can break down pollutants. Without onsite reuse, normal detention ponds cannot reduce the volume of runoff delivered downstream.



Southface photo

*Rainwater catchment is ideal for garden needs.*

- ✓ Create a rooftop rainwater collection system.

Collected rainwater has been used in many parts of the world since people began living in communities. While producing drinking water in this manner may be something to consider, at a minimum rooftop water can be easily collected and used as a substitute for well or city water for landscape irrigation.

- ✓ Create a household graywater collection system.

Another way to save even more water would be to recycle graywater. Graywater is the water that has been used in the shower, clothes washer, and dishwasher and is not contaminated with human waste. Graywater often can be used without treatment for subterranean irrigation of landscapes (just be sure to use low-nitrate, natural detergents). For use involving human contact, graywater *must* be treated.

- ✓ Create a constructed wetland for polluted and wastewater treatment.

Constructed wetlands are ecological alternatives to traditional municipal and onsite wastewater treatment systems. In addition, constructed wetlands can improve water quality below parking lots and waste disposal areas. Constructed wetlands typically do not replace all the functions of natural wetlands. Rather, they mimic the water purification capabilities of natural wetland systems and minimize water pollution prior to its entry into streams, lakes, and other waters.

---

*Water reuse ponds are a relatively inexpensive source of irrigation water. A 1993 study calculated that the cost of irrigating a 100-acre, 18-hole golf course at 2 inches per week can cost as much as \$300,000 a year, whereas the annual cost of pumped stormwater from a water reuse stormwater pond was only \$40,000 a year—a significant savings over potable water.*

---

## Practice 9

# Promote Environmental Awareness and Stewardship

### Why this practice is important

While creating a development with unique sustainable features will go a long way toward solving many environmental problems, if the builders, sellers, and owners of homes within the development are unaware of the importance of their actions over time, even the best land development practices can be compromised.

### The solution and its benefits

Each developer should create a set of guidelines for builders, realtors, and homeowners that explains the environmental performance characteristics of the development. First, it is critical that the positive benefits of the development be touted to the market. Second, it is important that homebuyers accept the goals of the development and actually contribute to the long-term success of the project.

## Here's What You Can Do

- ✓ Create a well-documented master plan including illustrations that promote sustainable aspects of the development.
- ✓ Include environmental builder specifications in all subcontracts.
- ✓ Produce detailed sales and promotion materials that feature conservation aspects of the development.
- ✓ Develop subdivision covenants that establish ground rules for the maintenance of shared open lands and individual lots.
- ✓ Create a Homebuyer's Environmental Instruction Guide that explains the unique environmental aspects of the subdivision and special maintenance considerations.

## CHAPTER THREE

# Sustainable Buildings: Floor Planning, Indoor Air Quality, Material Selection, and Waste Reduction

### Introduction

During the past several decades, home designs have increased in size and sophistication, resulting in greater environmental impact. But increased environmental impact does not have to result. Instead, by carefully considering efficient use of space, orienting homes for passive solar heating, natural cooling, and daylight and carefully selecting materials, builders can significantly lower material use, air quality problems, and energy consumption.

The typical 2,000-square-foot home uses 16,000 board feet of lumber, plus 6,000 square feet of plywood, all equal to several hundred trees. In addition, thousands of pounds of various other raw materials, some toxic, are extracted to produce interior and exterior finish products. In the process, large amounts of materials and energy are wasted. Builders typically send 4 tons of waste to the landfill for every 2,000-square-foot home. Better up-front planning plus recycling many of these materials can reduce disposal costs and extend landfill life.

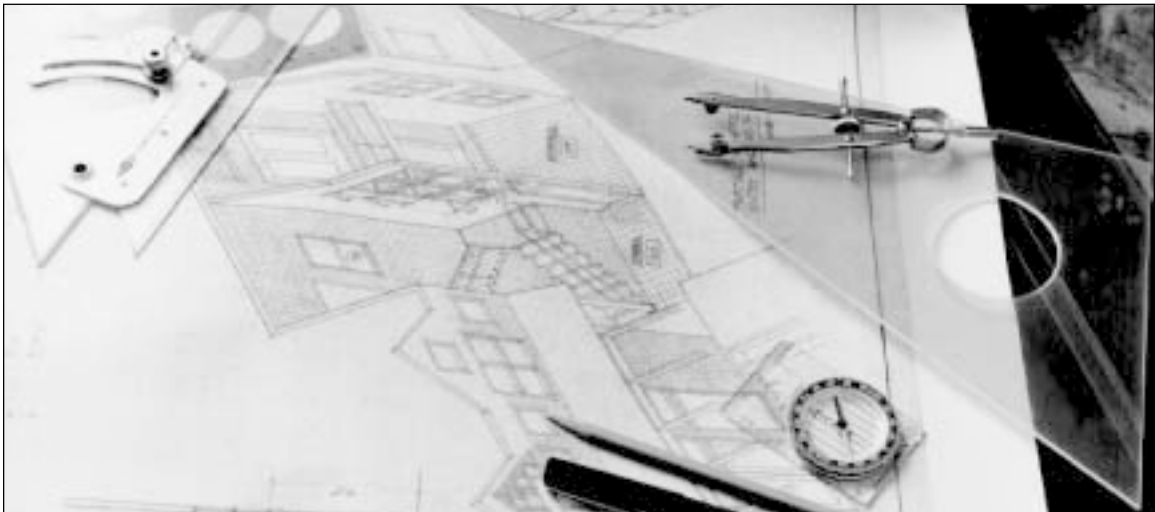

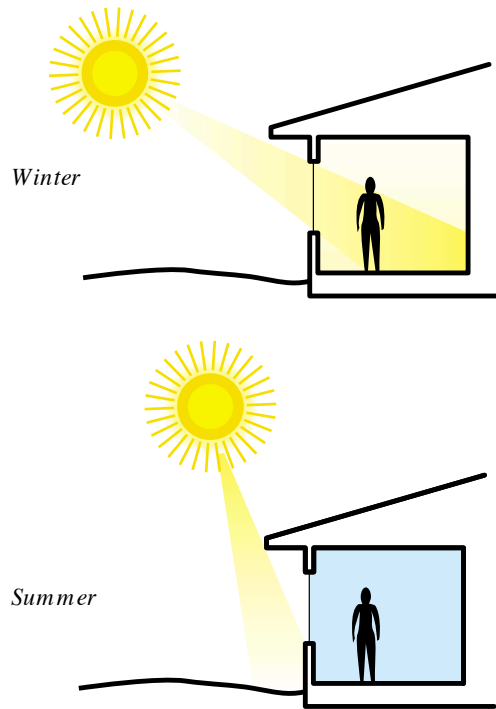

*Building orientation and passive solar design considerations control the amount of natural heating and cooling that a building receives.*

### A Summary of Sustainable Floor Planning, Indoor Air Quality, Material Selection, and Waste Reduction Practices

- ✓ Create efficient floor plans
- ✓ Orient buildings and windows for passive heating, cooling, and daylighting
- ✓ Specify sustainable and healthy building materials
- ✓ Design interiors that ensure healthy indoor air quality
- ✓ Prevent moisture, radon, and soil gases from entering homes
- ✓ Reduce job-site waste and use building materials efficiently

## Practice 1

### Create Efficient Floor Plans

#### Why this practice is important

The average home size in America has increased by a third (from 1,500 to 2,150 square feet) since 1971, while household size has decreased from 3.1 to 2.6 people. These figures mean that the typical home today provides more than 800 square feet per family member. The number of single-parent homes has exploded, and multigenerational homes rarely exist today. At the same time, two-income families spend less time at home than ever before. Because we are allocating far more space per person in our homes and occupying this space less frequently, we are creating needless environmental impacts through the amount of building materials used and the space that must be heated and cooled. Homes are often just “big” and not well planned, thus wasting space, increasing maintenance, and reducing quality of family life.

#### The solution and its benefits

Reducing the total square footage of homes will significantly reduce framing and finish material costs. These costs can be reallocated to other parts of the construction budget, emphasizing more functional yet aesthetically pleasing designs. Builders can profit by selling more features rather than just more square footage. In addition, less space means lower operating energy costs. Efficient floor planning is perhaps the single most important sustainable building practice available—and the easiest step to take.

#### Here’s What You Can Do

- ✓ Build in subdivisions that focus on open space preservation and shared community facilities—not just big lots and big homes.

- ✓ Build duplexes, townhomes, or homes with in-law suites that share walls.
- ✓ Support elimination of minimum home size regulations.
- ✓ Reallocate construction budgets to upgraded landscaping and finish materials.
- ✓ Sell better layouts, greater durability, comfort, and energy-efficiency features.
- ✓ Select plans that feature efficient space allocation. Consider the following:
  - *Share space between different uses.*  
A home office and guest bedroom is a common combination.
  - *Fill the entire building volume.*  
Keep usable space from being lost to attics.
  - *Reduce circulation paths.*  
Shorten or eliminate hallways, unless they serve a dual purpose.
  - *Build furniture into rooms.*  
Cabinets, bookcases, benches, and eating nooks use less space when they become part of the structure.
  - *Remove formal spaces.*  
Most people gather in kitchens and family rooms. Formal living and dining rooms are seldom used.
  - *Reduce size of bedrooms.*  
Most people use bedrooms primarily for sleeping, dressing, and little more.
  - *Provide ample storage.*  
When people want a "bigger house," they may actually need more storage.
  - *Enhance trim and detail.*  
High-quality details can be a key benefit of a small house.
  - *Add a focal point.*  
Each room should have at least one attractive feature.

---

### **Saving Old-Growth Forests for People and Animals**

*For an average home, conventional solid-wood framing can use more than 100 large trees (30-inch-diameter and 75-foot-height). Engineered lumber, once affordable only for high-end commercial construction, is an improvement over solid-sawn lumber and is now competitively priced for residential use. This material can use fast-growing farm trees instead of large-diameter old-growth trees and requires 50% less wood fiber to perform the same structural functions. In addition, the superior spanning properties of engineered lumber permit open space floor planning that can reduce partition walls and finish material and increase home value.*

---

- *Invite natural light.*  
Careful selection, sizing, and location of windows and light wells can flood a small space with natural light without increasing energy use.
- *Bring in the outdoors.*  
Locate windows and glazed doors next to decks, patios, courtyards, and porches.
- *Tie spaces together.*  
Similar materials, such as flooring, wall coverings, and trim, tie spaces together visually, giving the overall impression of greater space.
- *Separate spaces.*  
Instead of building a wall, change floor coverings, expose a beam or hang a pot rack.
- *Plan for flexibility.*  
The design should allow for changes in lifestyle.

## Practice 2

# Orient Buildings and Windows for Passive Solar Heating, Cooling, and Daylighting

### Why this practice is important

Proper building orientation can reduce home energy use at little or no cost. Building lots are often laid out without regard to the movement of the sun, and glass placement decisions are based solely on the aesthetics. As a result, building heating and cooling systems must be larger to fight the sun in summer and make up for heat lost during winter. In addition, hot and cool zones in the house make homeowners uncomfortable and cause them to constantly adjust the thermostat to compensate.

Most homes either have too little natural lighting or have improperly located windows and skylights that cause energy and comfort penalties, as well as faded interior furnishings. Reliance on artificial lighting both day and night is wasteful and expensive.

Disregard of solar design decisions can cost homebuyers twice. First, heating and cooling equipment must be larger: an extra half-ton on an air conditioner can cost up to \$800 per home. Second, poor solar orientation can increase annual energy costs by 10 to 25%. The extra pollution penalty is significant when multiplied by the thousands of homes built each year.

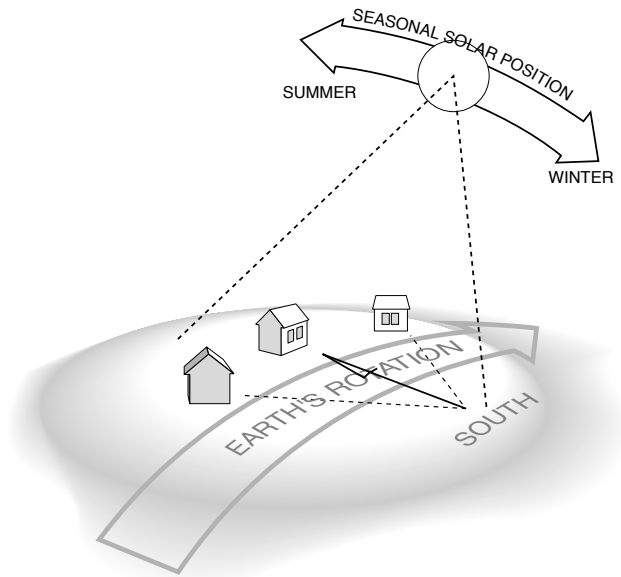

*The south face of a home receives three times more solar heat in winter than east or west faces. In summer, east and west faces receive the most solar heat.*

### The solution and its benefits

Proper orientation of buildings is one of the least expensive energy features of a home. In addition to energy saved, homes are more comfortable and keep around a ton of carbon dioxide per home out of the atmosphere each year.

Today, homes can be designed that take maximum advantage of the latest window and daylighting technology to reduce lighting energy use. If we don't do so, lighting costs in homes will increase as more people establish home offices and use them during the day.

Home designs that take advantage of smart daylighting features not only look and feel more attractive to buyers, they can also be sold as an important energy-saving, pollution-prevention feature of a green home program. The key to the success of using daylight to save energy is careful placement of energy-efficient windows as well as use of other advanced options to bring light into buildings that do not cause a summer cooling penalty.



## Here's What You Can Do

The following design tips will make a significant impact in energy use and home comfort:

- ✓ Lay out subdivision lot lines so that the maximum number of buildings can be oriented with the long side aligned within 15 degrees of north or south.

During the master planning phase of a subdivision, select building sites and street layouts to maximize lots with access to passive solar benefits. (This action is especially important in compact developments with narrow lots that limit building alignment choices.) Lay out buildings so that the long side of the home is facing as close to due south as possible.

- ✓ Orient building footprints to within 15 degrees of the east-west axis.
- ✓ Organize the floor plan to complement passive solar orientation.
  - Place day-use spaces (living rooms, dens, kitchens) on the south side.
  - Place garages, storage rooms, or other unconditioned “buffer” rooms on the east or west side.
  - Place bedrooms on the east or north side.
  - Place porches on the east and west side to provide shading.
- ✓ Optimize the glass area and orientation.
  - Maximize the glass area on the south (5 to 20% of floor area).
  - Place a moderate amount of glass on the north to allow daylighting.
  - Minimize or eliminate glass on the east and west. Unless these sides are completely shaded during the day, avoid relying on east- and west-facing glass for daylighting.

- ✓ Choose glass and shading devices to match wall orientation.
  - Use insulated, low-E, gas-filled glass to maximize R-value, increase comfort, and reduce ultraviolet fading of materials.
  - Use shade screen or high-shade-coefficient glass on the east and west sides to reduce solar gain by up to 80%.
  - Minimize overhead glass to reduce summer solar gain.
- ✓ Specify tile or masonry floors in south-facing “sun rooms” to absorb solar radiation.
  - For maximum benefit, specify a “slab-on-grade” floor or install a 2- to 4-inch-thick mortar base under tile.
  - Avoid carpet in rooms designed to absorb solar radiation.
- ✓ Use overhangs and awnings.

An essential feature of passive solar design is appropriate summer shading of south-facing glass. The further south the home is and the closer to the floor a window is located, the longer the overhang needs to be. The length can range from 2 to 4 feet in most parts of the Southeast, with 2 feet being the most common.

- ✓ Minimize use of skylights except on north-facing roof slopes.

Skylights can offer pleasant natural lighting but can cause heat gain and glare problems when direct sunlight passes through them into rooms. Poor insulating qualities of skylights also cause reductions in thermal performance. And skylights are notorious for causing roof leaks. Choose skylights that offer double glazing, low-E coatings, and superior waterproofing features.

- ✓ Consider new “light pipes” instead of skylights.

Light pipes or sun tubes capture daylight in a glazed bubble on the roof and pass the light through a reflective tube through the attic into a light-diffusing lens mounted in the ceiling. With an insulating value of up to R-22 and a color rendering index (CRI) rating of 98.7, light tubes offer an inexpensive alternative to traditional skylights.

- ✓ Choose light-colored interior surfaces.

To maximize the effect of natural lighting, walls and interior surfaces should be lighter in color. (*Note: Darker surfaces should be specified on thermal mass surfaces used to absorb heat in passive solar homes.*)

---

### A Future in the Sun

*In addition to passive heating, the Southface Energy and Environmental Resource Center produces electricity from the sun with about 500 square feet of photovoltaic roof shingles. The power produced is enough to supply the electrical needs of a small home that uses energy-efficient appliances and lighting, as well as natural cooling (no air conditioning).*



*The federal government's Million Solar Roofs Initiative has a goal of installing one million solar energy systems by the year 2010, which DOE estimates will save the equivalent of 850,000 cars worth of pollution annually.*

---

## Practice 3

---

# Specify Sustainable and Healthful Building Materials

---

### Why this practice is important

Choosing to build green requires knowledge. Some building materials such as plywood and dimensional lumber milled from dwindling old-growth timber harm the environment. The energy used for production or distribution of a material also has an impact on the environment. While the immediate penalty for use of some materials may seem remote, the cumulative effect on global air and water quality is significant. For example, the energy used to produce, transport, and install building materials (called *embodied energy*) can equal 25% of the total energy used during the life of the home for heating, cooling, hot water, lighting, and operating appliances.

### The solution and its benefits

Today, builders have more environmentally friendly material choices than ever before. While cost will always be a driving force, many products have little or no additional cost. Incorporating these materials into a building program may take time and research, but the benefits can be significant, including

- Discovery of superior-performing or less expensive products
- Marketing advantages from using sustainable materials
- Cost-effective changes in construction practices
- Improved worker and homeowner satisfaction
- Waste reduction
- Reduction in embodied energy

## Here's What You Can Do

Adapting 100% sustainable building products and materials is rarely realistic, but it is important to use environmentally improved products whenever practical. Steve Loken, a builder and founder of the Center for Resourceful Building Technology, notes that “making a 10% change on 90% of your projects makes an enormous difference over time.”

- ✓ Select sustainable building materials with as many of the following qualities as possible:
  - Durable and providing long-lasting benefits
  - Low embodied energy
  - Produced locally or regionally
  - Made with some quantity of post-industrial or post-consumer recycled materials
  - Easily salvageable or recyclable
  - Derived from salvaged materials
  - Mined or produced in a less environmentally hazardous or toxic manner
  - Do not contribute to ozone depletion
  - Do not off-gas or leach pollutants
  - Minimize packaging waste

Selecting the most sustainable building materials is not easy. Rarely can a material meet all of the above specifications. So, the way to make selections is to determine which material from a range of choices for a particular function is more sustainable or resource-efficient than another product.

Also, the environmental impact of a material needs to be prioritized. A material that reduces energy use 10% probably reduces pollution much more than a product featuring 10% recycled content. If the budget is restricted, the energy-saving product is probably the better choice.

## The Impact of Reducing Embodied Energy

*For a high-energy-performance building, the amount of total energy used over 20 years could be less than what was required to build it. One study in Canada estimated that the total embodied energy for a standard (not energy-efficient) house was 2,352 gigajoules, or GJ (one GJ equals one million Btu). The operating energy over 40 years was calculated at 9,060 GJ, meaning that it would take about 10 years before the cumulative operating energy would match the amount of embodied energy in the house. While reducing operating energy is the most important priority because of the large energy-saving opportunities over the long life of a building, reducing embodied energy is also a major part of the sustainable equation.*

- ✓ Consider overriding building product priorities.

In evaluating sustainable building products, keep in mind the following priorities, listed in order of importance:

1. *Durability and structural integrity of the building*

Materials that protect the building from weather, termites, and other risks must be durable. Siding made of cement and wood-fiber composite is an excellent choice because these materials are both durable and have recycled content.

2. *Health and safety of building occupants*

Materials must not jeopardize the health of building occupants. For example, damp spray cellulose is an excellent insulation but must be thoroughly dry before enclosure to prevent mold growth.

3. *Long-term operating energy efficiency of the building.*

First and foremost, materials that form part of the thermal envelope (including ducts) must be energy-efficient. Cellulose insulation is an example of a product that is both sustainable and energy-efficient. Similarly, while energy-efficient glazing may have high embodied energy costs from long-distance transport (up to 33% of total embodied energy), over the life of the building, it is still a better choice than locally made, single-pane glass.

☑ Incorporate sustainable materials.

Begin now to learn about and incorporate into building projects these sustainable materials:

- Cement/ wood-fiber composite siding (50-year rating and reduced fire insurance rates)
- Structural insulated panels made with oriented strand board (OSB)
- Cellulose insulation
- Engineered lumber products (gluelam, microlam, paralams, wood “I” joists)
- Plastic lumber made from recycled materials or lumber recovered from demolished buildings
- Certified lumber harvested from sustainable yield forests
- Concrete made with fly ash
- Floor tiles made with recycled materials
- Steel framing (for interior framing)
- Autoclaved concrete
- Carpet made of recycled fibers that is itself recyclable
- Wood-finish materials made from salvaged wood or timber
- Roof systems that provide 30 or more years of life (reduces reroofing waste)
- Finger-jointed trim and framing.

---

**Consider Recycled Building Products**

*While steel framing and roofing carry a heavy energy penalty, metal is easily recyclable and currently contains up to 25% recycled content.*

*This amount is likely to increase with new steel-making technology. Concrete is available with recycled fly ash, a by-product from coal burning used as an additive that improves strength and reduces Portland cement content by up to a third.*

*Cellulose insulation has a high recycled-paper content (more than 75%), while some fiberglass products have about 25% recycled glass content.*

*Composite materials such as fiber-cement siding have 5% or less recycled fiber content but offer long-term durability.*

---



Southface photo

*Sustainable products, ranging from structural insulated panels made with oriented strand board to carpets made from recycled plastic, offer home builders an opportunity to reduce environmental impacts and resource use, as well as improve worker and homeowner health, often at little or no additional cost.*

✓ Phase in sustainable building materials.

The following guidelines will make progress toward sustainable building materials more likely and allow for continuous improvement over time:

- Replace conventional framing and siding materials with engineered lumber, trusses, and cement-fiber siding for immediate impact.
- Choose materials that contractors can easily substitute, such as floor tiles or carpet that are made from recycled materials and are recyclable.
- Select materials used by contractors who already promote their own green building options.
- Consider materials that consumers will easily recognize as green.
- Become a certified green builder through your local home builders' association.
- Work with manufacturers to use advanced products on a “test” or “model” house.

## Design Interiors That Ensure Healthy Indoor Air Quality

### Why this practice is important

While many toxins exist throughout the environment, indoor air quality (IAQ) is a growing concern. The EPA has reported that air inside homes can be more polluted than that outdoors. Indoor pollutants result from both chemical and biological sources. Examples of common indoor air pollutants include molds, dust mites, excess moisture, combustion gases, radon, and chemicals like volatile organic compounds (VOCs). Experts believe these pollutants can be dangerous and can especially affect the health of children, the elderly, and anyone with illness. Continued exposure to even low levels of indoor air pollutants can be linked to a vast spectrum of illnesses, including chronic sinus infections, headaches, insomnia, anxiety, joint pain, cancer, and immune systems disorders.

### The solution and its benefits

Every day, a growing number of manufacturers are introducing building products that significantly reduce potential toxins and VOCs in the home. Many health and safety issues can be addressed through attention to healthy materials and design features. In many cases, the added costs of specifying these materials is no greater or only marginally higher than standard materials, and the health benefits are well worth the investment. When builders combine use of these materials with improved ventilation and air-filtration systems, they have significant opportunities to market homes built to a higher IAQ standard to upscale buyers. All homes built today should take IAQ into consideration for the health and safety of occupants.

### Here's What You Can Do

The following commonsense measures will greatly improve IAQ in the homes you build:

- ✓ Control relative humidity to between 30 and 50%.

Effective drainage, proper air sealing, controlled ventilation, and “right-sized” heating, ventilating, and air conditioning (HVAC) systems are key.

- ✓ Install airtight ducts and properly balanced duct systems.

Poor duct design and installation often increases energy costs by more than 20% and can endanger health and safety. Locate ducts in conditioned space whenever possible.

- ✓ Use radon-resistant construction.

When properly installed, radon-resistant construction (see Practice 5) reduces the amount of radon entering a home and provides moisture resistance as well.

- ✓ Specify low- or no-VOC paints, adhesives, and finishes.

Because paints and sealers can off-gas VOCs for months, use low-VOC paints and adhesives and water-based wood finishes. Prefinished wood floors are completely cured before entering the home.

- ✓ Specify natural or low-VOC flooring products.

The numerous products on the market include cork, linoleum (linseed-oil-based), sisal, jute, wool, sea grass, and bamboo composite flooring.

- ✓ Specify carpeting and cabinets with low or no formaldehyde content.

Select solid wood cabinets (or completely sealed particle board components), solid countertops, and carpets with low piles and urethane pads.

- ✓ Isolate combustion appliances from conditioned areas.

Backdrafting combustion appliances are a major cause of toxicity in homes. Tight homes must separate the “makeup” air of these appliances from the home’s conditioned air and provide power venting.

- ✓ Avoid locating HVAC systems where paints, chemicals, and fuels are likely to be stored.

Ensure that forced-air systems do not create pressure imbalances that can draw these toxins into the home.

- ✓ Provide storage areas for cleaning products away from return vents.
- ✓ Inform homebuyers about options to reduce or replace the use of household chemicals like bleach and ammonia.

Include information about alternate cleaners like borate, vinegar, baking soda, and other biodegradable detergents in home buyer guides. This action is particularly important if the home has graywater harvesting.

- ✓ Install a central vacuum cleaning system.

A central vacuum system eliminates a tremendous amount of dust that is recirculated by standard vacuum cleaners.

- ✓ Provide controlled ventilation — ventilation by “air leakage” cannot be relied upon. Consider one of these options:
  - *Enhanced Spot Ventilation*  
Allow for ventilation through high-quality kitchen and bathroom exhaust fans.

- *Whole-House Ventilation System*

A centralized exhaust fan is connected to multiple vents in the house, especially the bathrooms and kitchen. The exhaust fan is usually coupled with a dampered outside air intake vent connected to the HVAC ducts. When the fan is on, fresh air is distributed through the house. The central fan can be timed to turn on at regular intervals or can be controlled by a humidity sensor.

- *Heat Recovery Ventilation System*

Also based on a centralized exhaust fan, this system saves energy by tempering incoming air with the exhausted air. Stale air passes through an air-to-air heat exchanger and warms (or cools in summer) incoming fresh air. The ventilation system can be timed to turn on at regular intervals or be controlled by a humidity sensor. An added benefit when installing an “enthalpy” recovery unit is dehumidification.

- *Dehumidifier Ventilation System*

A dehumidifier ventilation system provides for fresh air ventilation where the air is cleaned, dehumidified, and distributed throughout the home.

A high-efficiency dehumidifier uses a refrigerant to cool the air below its dewpoint, the temperature at which moisture condenses out of the air. This process removes latent heat; the resulting liquid water, or condensate, is drained to outside the building. The cooled, dry air then passes over the condenser coil, where heat is transferred from the refrigerant into the air, thus heating it back up to slightly above room temperature. Special controls on the unit allow it to activate a motorized damper to adjust the amount of outdoor air taken in and to continuously circulate air for filtration independent of the dehumidification cycle.

## Practice 5

# Prevent Moisture, Radon, and Soil Gases from Entering Homes

### Why this practice is important

In the Southeast, high humidity levels create multiple problems for homes. In addition to the obvious problems associated with humidity, such as mold and doors that stick in the summer, billions of microscopic allergens breed in homes when relative humidity climbs above 50%. For many people with respiratory conditions, high humidity can be a serious health threat. Air-conditioning equipment must work extra hard to remove moisture from homes; moisture reduction is responsible for a significant portion of summer cooling bills.

Radon is a colorless, odorless radioactive gas that occurs in soils; it can seep from soils into homes. Radon is the second leading cause of lung cancer in the United States (14,000 deaths per year) after cigarette smoking. For both new and existing homes, the seller is obliged to disclose any knowledge of a radon problem. While homes can be tested for radon after construction, fixing the problem after the fact can be expensive. Radon-resistant construction practices add little to new home costs and help reduce moisture and soil gas levels in the homes.



### The solution and its benefits

Preventing moisture, radon, and soil gases from entering homes is a relatively easy and cost-effective step to take during construction. Typical benefits include

- Greatly reduced exposure to radon gas
- Reduction in exposure to pesticides and other chemicals stored in basements or crawlspaces
- Reduction in mold spores and other microscopic allergens
- Reduction in HVAC equipment size
- Reduction in cooling loads
- Increased use and longevity of furnishings and other personal property



## Here's What You Can Do

Radon levels vary from region to region and house to house in a neighborhood. The only sure way to know is to test for radon. Moisture and soil gas reduction must be tackled at both their source and at the point of entry into the home. The following tips will go a long way toward decreasing moisture, radon, and soil gases entry into homes.

### ✓ Air-seal homes.

Sealing all penetrations, especially in the floor area, is vital to stopping radon, soil gases, and moisture from entering the home.

### ✓ Keep water away from foundations and walls.

Specify proper surface drainage and downspout details to keep moisture away from foundations and crawlspaces. Consider drainage boards for below-grade foundation walls. Prevent rain from penetrating walls with good overhangs, flashing details, and proper use of building paper.

### ✓ Protect concrete slabs from groundwater.

Install a 4-inch layer of gravel as a capillary break below slab floors. Cover gravel with 6-mil polyethylene.

### ✓ Install 6-mil plastic-sheet ground cover in the crawlspace; do not vent.

In a standard crawlspace, cover all exposed soil with an unbroken layer of 6-mil plastic sheeting. Do not vent crawlspaces. Research shows that with air-conditioned homes, moisture problems are created by venting cool crawlspaces with warm, humid air. Protect crawlspaces from outside moisture and groundwater and keep sealed.

### ✓ Use radon-resistant construction.

- Place a 4-inch layer of gravel beneath slabs.
- Cover the gravel with a 6-mil plastic sheet.

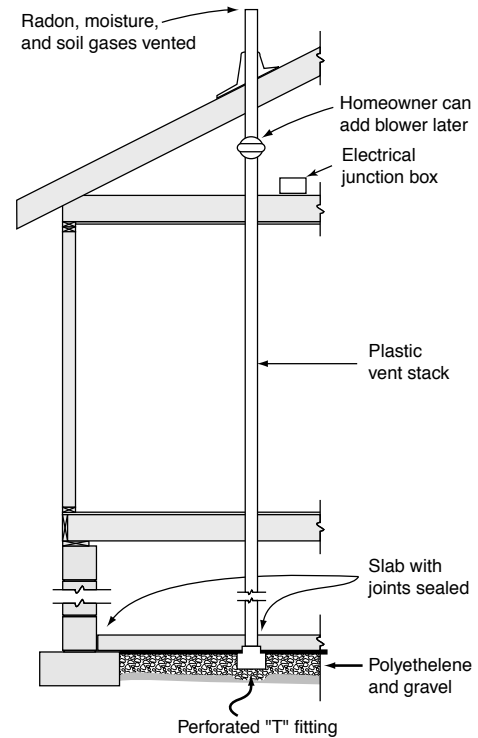

*Radon-resistant construction is a contingency measure that saves the time and expense to reduce radon levels in the event that radon is detected in a newly constructed home.*

- Install a 4-inch polyvinylchloride (PVC) “T” section below the plastic, with a vertical pipe section extending above the plastic.
- When using slab construction, leave the PVC “T” below the concrete with the vertical pipe above the slab.
- Have the vent pipe extend through interior walls and through the roof.
- Install an electrical junction box in the attic in case a fan needs to be added to the vent pipe. (Radon testing after construction is complete will determine if this extra venting is required.)
- Carefully seal all joints and penetrations in the concrete slab or crawlspace with long-lasting caulk.

## Practice 6

# Reduce Job-Site Waste and Use Building Materials Efficiently

### Why this practice is important

Typically, builders dispose of between 3 and 5 tons of materials for every 2,000-square-foot home built. Wood, drywall, and cardboard amount to nearly 80% of all job-site waste. In some regions, cardboard alone constitutes 40% of waste by volume, taking up valuable space in waste containers that must be hauled and dumped in increasingly scarce landfills.

### The solution and its benefits

Reducing job-site waste and recycling is beneficial both to builders and to the environment. Where tipping fees are above \$50 a ton, builders can save more than 20% of their total disposal costs. In addition, if used as part of a green building strategy, job-site waste reduction and recycling can be a visible sign of a company's commitment to the environment. Finally, waste-disposal costs are likely to increase over time, so beginning now can create work habits and systems that can keep costs low in the future.

Typical Construction Waste by Material	
Material	Weight per House (2,000 sq ft)
Wood	1.7 tons
Drywall	1 ton
Cardboard	400 lbs
Metals	150 lbs
Other	750 lbs
<b>Total</b>	<b>4 tons</b>



Benefits from waste reduction and recycling include

- Savings on material costs
- Waste-disposal cost reductions
- Better job-site organization and cleanliness
- Improved environmental image
- Extended life of landfills
- Reduction in embodied energy costs of construction
- Avoidance of new government regulations

*Builder Dan Kent in Wilmington, North Carolina, is pleased with the cleanup service he hired to handle his job-site recycling. He estimates that Site Clean saves him around \$600 per house while he can take credit for this green building activity. Site Clean pays about six or seven site visits per job. The visits are timed to recover materials at each construction phase. Materials contained on site in an 8 x 8 x 4-foot fenced area are loaded into dump trucks with a bobcat.*

## Here's What You Can Do

Initiating waste reduction is easier where a developed market and job-site recycling system already exist. Local waste-disposal haulers can indicate what is currently available. The start-up process is always the most difficult because it is a change in standard practice for crews and contractors. Finding someone to take on the challenge of organizing a new system can be effective. Finally, think of rewards to offer crews, such as the “cleanest crew” award tied to incentives at the end of the week.

### ✓ Initiate job-site recycling.

There are four main options for job-site waste recycling programs. The options require an increasing level of builder input and crew participation.

- *Job-site cleanup and recycling service*  
While not currently available in many areas, such operations can save builders up to \$600 on a typical 3,000-square-foot home.
- *Commingled recovery*  
Contractors place mixed waste in haul-off containers, which are sent to a recycling facility instead of the landfill. While savings may be small, the knowledge that materials are being diverted from the landfill allows builders to promote this green practice.
- *Job-site separation and recovery*  
While this option requires builders to work with trades to separate their waste, it is a visible green building activity. Typical savings on disposal costs are around 20%.
- *Self-hauling*  
The potential disposal savings for this system are up to 45% if the builder can incorporate frequent hauling to conveniently located recycling centers into the regular routine. Builders large enough to dedicate a crew to full-time waste management or small enough to make waste management part of their daily pickup and delivery duties are best suited for self-hauling.

### ✓ Implement other waste-reduction and reuse strategies.

- *Use panelized construction and trusses.*  
Factory-built components waste less because the factory's profits are based on low or no waste.
- *Give framing and drywall contractors a tight materials allowance or have them supply all material.*  
If the cost of waste is placed with the contractor, waste will decrease.
- *Require contractors to haul off their own waste materials.*  
Contractors will reduce waste if they have to pay the cost of removal.
- *Pay contractors a bonus if they reduce waste disposal costs from a set level.*  
The reduction of one haul-off container can be worth \$270 plus the cost of placing those materials in the container. Give contractors the cost of the container saved and keep the cleanup labor savings as profit.

### ✓ Practice deconstruction and salvage.

Each year, as many as 100,000 homes are demolished in the United States. The demolitions result in more than 8 million tons of wood, plaster and

---

*A major builder of homes in the Atlanta market typically pays about \$1,500 for waste removal per 3,000-square-foot home. This amount includes the cost of three haul-offs—two just for wood scraps plus a final cleanup service for cardboard and carpet scraps at the end of the job. A special crew is required just to pick up after contractors who refuse to place their waste in containers. Most of the waste is generated by framing crews, who are paid only for their labor and use the builder's lumber inefficiently.*

---

drywall, metals, masonry, and other building materials, most of which will end up in local landfills.

Builders and remodelers often discard large quantities of valuable materials out of ignorance or haste. With a little planning and a place to store, sell, or donate materials (sometimes donations are tax-deductible), waste can be greatly reduced. Especially valuable are large-dimension framing materials, 2x4s that can be used for bracing and blocking, hardwood floors, bathroom fixtures, windows, doors, and cabinets. Many volume builders end up with extra windows and doors that can be easily donated to a nonprofit salvage center that may even pick up from job sites.

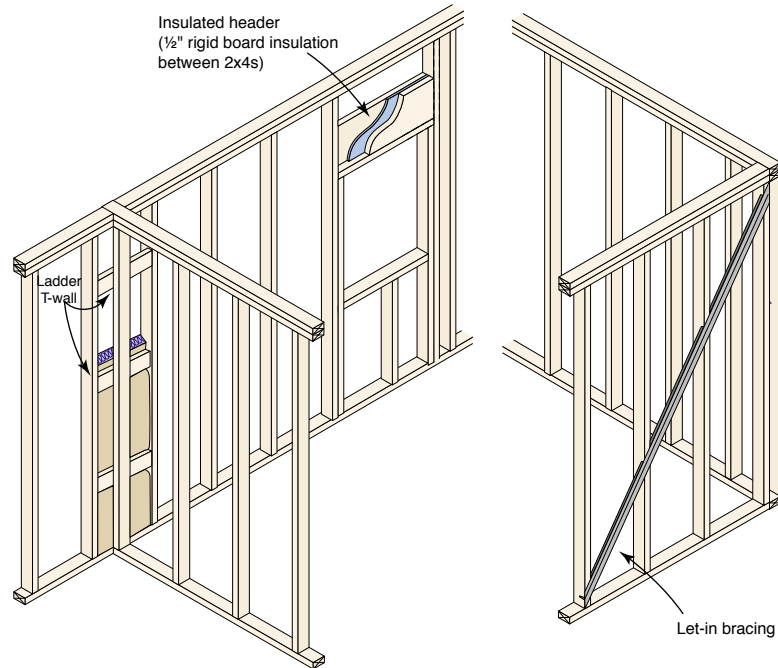

*Optimum Value Engineering employs techniques to allow for greater coverage of insulation in addition to resource savings.*

✓ Use source reduction and Optimum Value Engineering (OVE) practices.

Effective source reduction begins at the design phase and during material purchase. According to the *Journal of Light Construction*, overpurchasing and wasting materials on the job site are the number one “profit killer” for builders. Using an OVE approach to residential construction pioneered by the National Association of Home Builders Research Center in the 1970s can save hundreds of dollars and tons of waste on each job.

The following are basic OVE principles:

- *Align structural members.*  
Structural members from foundation to roof should be spaced at the same modular dimension to facilitate construction for the framers, transfer loads directly through the supporting members to the foundation, and reduce the amount of material to be used.
- *Base home designs on 2-foot dimensions.*  
Most building materials come in 2-foot modules. Carefully lay out building dimensions to eliminate odd-sized “cutoffs.”

- *Size and place windows to fall in line with stud layout.*  
Avoid window sizes and placements that require additional studs placed closely together. In addition to waste, an energy penalty is paid.
- *Use open space planning.*  
Thanks to engineered beams and floor trusses, fewer load-bearing walls are required to break long spans. Use of open floor plans reduces partition wall framing and drywall.
- *Use energy-efficient framing details.*  
Because extra wood in exterior walls reduces energy efficiency, use energy-efficient corners and partition wall intersections. In addition to greatly reducing the number of studs used, more insulation can be placed in cavities not filled with structurally unnecessary studs. Even better, consider going to 19.2-inch or 24-inch spacing for all framing members. Not only is the R-value of the envelope increased, but overall framing lumber use is reduced by up to 30%.

## CHAPTER FOUR

# Sustainable Building: Energy-Efficient Design and Construction

### Introduction

Building an energy-efficient home requires dozen of decisions by home designers, builders, and subcontractors. Many decisions affect the cost for construction and the profitability of the project. While energy efficiency requires careful planning and attention to details throughout the construction process, it offers substantial benefits to building professionals:

- Fewer callbacks due to drywall cracks, nail pops, moisture, and other problems
- Reduced liability from failure to comply with building, fire, and energy codes
- Enhanced design and construction flexibility due to smaller and simpler mechanical systems
- Increased markets due to energy-efficient mortgages and other incentives
- Greater customer satisfaction because of improved comfort, less noise, reduced maintenance, increased durability, fewer pests and rodents, and lower operating costs
- Recognition as a professional dedicated to quality and protecting the environment



Photo courtesy of Orietta A. Frame

In addition to benefiting the builder, energy-efficient homes save homeowners money—typically \$300 to \$600 a year. Energy features also enhance the health, safety, comfort, and durability of a home. Reducing energy waste protects the environment, especially in the South, where there are many older coal-fired electric power plants. In some areas, up to 40% of all air pollution can be attributed to electric power plants. Each year, the typical energy-efficient home prevents over 10,000 pounds of pollutants that cause smog, acid rain, global warming, and other environmental stresses.

### The House as a System

Successful design and construction professionals follow a “systems” approach to improving the energy efficiency of their homes. A systems approach considers the interaction between the site, the building envelope, the mechanical equipment, occupants, and other factors. A systems approach recognizes that features of one component of the house can greatly affect others.

For example, energy-efficient windows cost more than standard products; however, they reduce heating and cooling needs, which reduces the size of the mechanical equipment. The reduction in size saves money on the purchase and installation cost of the mechanical equipment, which pays for the better windows. In addition to saving energy, the windows reduce condensation, which enhances durability and prevents mold.

Home construction has changed dramatically during the past 20 years. Most builders realize that today’s homes have tighter envelopes, increased insulation levels, and higher-efficiency mechanical systems and appliances. However, many building professionals do not realize that these improvements have not tapped the full potential for saving energy. When approached piecemeal and without consistency, some of these improvements can endanger the health, safety, and durability of the building.

For example, increased insulation slows heat flow but also reduces the ability of the building envelope to dry. If the envelope is not thoroughly sealed against air leaks, moisture-laden air can enter and cause problems.

### A Summary of Sustainable Building Energy-Efficient Design and Construction Practices

- ✓ Create continuous air barriers
- ✓ Create continuous insulation barriers
- ✓ Specify properly sized, high-efficiency HVAC equipment
- ✓ Design and install ductwork and filters properly
- ✓ Prevent interior moisture buildup with controlled ventilation
- ✓ Specify energy-efficient windows and doors
- ✓ Install energy-efficient water heating
- ✓ Design energy-efficient lighting
- ✓ Specify high-quality, water-saving faucets and fixtures
- ✓ Specify energy-efficient refrigerators and appliances



The U.S. Department of Energy and the U.S. Environmental Protection Agency sponsor ENERGY STAR Homes, a program that requires that homes be at least 30% more efficient than the national Model Energy Code (MEC). This high standard must be certified by a third-party home energy rater. Builders select the energy features that work best for a particular building design or process.

ENERGY STAR Homes feature improved comfort, indoor air quality, and construction quality, as well as higher resale value. The ENERGY STAR rating is a status symbol indicating a home meets a high standard of energy and environmental excellence. In addition, ENERGY STAR Homes save homebuyers money on monthly utility bills. These homebuyer benefits result in more satisfied customers, increased referrals, and reduced callbacks.

More than 2,000 builders and developers are currently participating as partners in the ENERGY STAR Homes Program. In the past year, they built nearly 6,000 homes, saving on average \$400 per home in annual energy costs.

## Practice 1

### Create a Continuous Air Barrier

#### Why this practice is important

Air leakage can account for more than 50% of a home's heating and cooling costs. It also contributes to problems with moisture, radon levels, comfort, noise, dust, insects, and rodents. Commonly used sheet materials—such as drywall, sheathing, and decking—are effective at reducing air leakage. The key is to seal all holes and seams between the sheet materials to create a continuous air barrier.

#### The solution and its benefits

It just makes sense to seal the big holes first, then the large cracks and penetrations, and finally the

smaller cracks and seams. Many times unseen holes or pathways, called bypasses, occur at key junctures in the framing (such as an attic-to-kneewall transition) and permit large quantities of air containing contaminants to leak in and out of a home.

Sealing the attic and floors should be focused on first, as the walls represent a less serious problem. Dropped soffit ceilings, ductwork and plumbing chases, leaky recessed light fixtures, wire penetrations, and pull-down stairs represent connections between the attic and the conditioned space. Major leakage sites in the floor can be found under the tub drain and at the numerous plumbing, HVAC, and wiring penetrations. In walls, the bottom and top plates, fireplaces with chimney inserts, the band joist (for two-story houses), and the window and door rough openings are primary leakage sites.

Benefits from air sealing include

- Significant increases in energy efficiency and comfort
- Reduction in size of HVAC equipment
- Fewer callbacks from moisture-related problems (visible mold, drywall pops and cracks, sweating on walls and windows)
- Increased structural durability and fire safety (from draft stopping)
- Improved control of relative humidity and indoor smells
- Reduction in radon levels, mold spores, dust mites, and other air quality problems caused by infiltration
- Quieter homes that are easier to clean
- Reduced insect and rodent problems
- Reduction in carbon dioxide, sulfur dioxide, and nitrogen oxides, all of which are major components of local air pollution and global warming.

## Here's What You Can Do

### ✓ Before drywall

- Seal bottom plate of exterior walls with caulk or sill seal; seal inside edge with caulk after walls are up.
- Seal band joist area with caulk, spray foam, or gasketing between top plate and band joist, and between band joist and subfloor.
- For bathtubs on outside walls, insulate the exterior wall and air-seal behind the tub with sheet goods before the tub is installed. After the drain is installed, seal the tub drain penetration with rigid foam insulation and spray foam.
- For dropped soffit cabinets and showers, use sheet material and sealant to stop air leakage from the attic into the soffit and then insulate. Alternately, frame and install drywall for the soffit area *after* the taped ceiling drywall is installed.

- Seal windows and exterior doors with backer rod and caulk or spray foam. Be cautious in using spray foam because it can expand and pinch jambs and may void some window warranties.
- Seal all electrical wire, plumbing, and HVAC penetrations between any conditioned and unconditioned spaces.
- Specify that all recessed lights connecting to unconditioned space be rated for insulation coverage (IC) and meet the ASTM E283 air-leakage rating.

### ✓ After drywall

- Seal electrical switch and outlet boxes to drywall with caulk.
- Seal light fixture boxes to drywall with caulk or foam.
- Seal bath and kitchen ventilation fans to drywall with caulk or foam.
- Seal all duct boots to floor or drywall with caulk, foam, or mastic.
- Seal any plumbing penetration through drywall with caulk or foam.
- If not done before drywall, seal tub drain penetrations (from the crawlspace side) with sheet material and caulk or foam.
- Seal gaps at the whole-house fan with spray foam or housewrap tape (ensure that louvers function properly).
- Fabricate the whole-house fan cover from rigid foam insulation and contact paper; attach with Velcro or wood frame bolted to ceiling. Or, if attic access is easy, build a cover from rigid foam or duct board that is placed over the fan from the attic side.
- For attic hatches, insulate the top of the board with at least 2 inches of rigid foam insulation or fiberglass batt; seal with weatherstripping. Use these same steps for short and full-size attic kneewall access doors and include a tight latch.



- For attic pull-down stairs, use a rigid foam cover kit; make stairs airtight using latch bolts and weatherstripping.
- ✓ **Air-seal the exterior:**
  - Seal all exterior penetrations—such as porch light fixtures, phone, security, cable and electric service holes—with caulk or spray foam.
  - Repair or replace any missing sheathing prior to installing exterior finish.
- ✓ **If in stalling housewrap:**
  - Seal top and bottom edges past the plates with housewrap tape or caulk.
  - Seal housewrap at windows and doors.
  - Overlap seams and seal with caulk or housewrap tape; seal all penetrations.
  - If not using housewrap, seal all sheathing seams with housewrap tape or caulk.

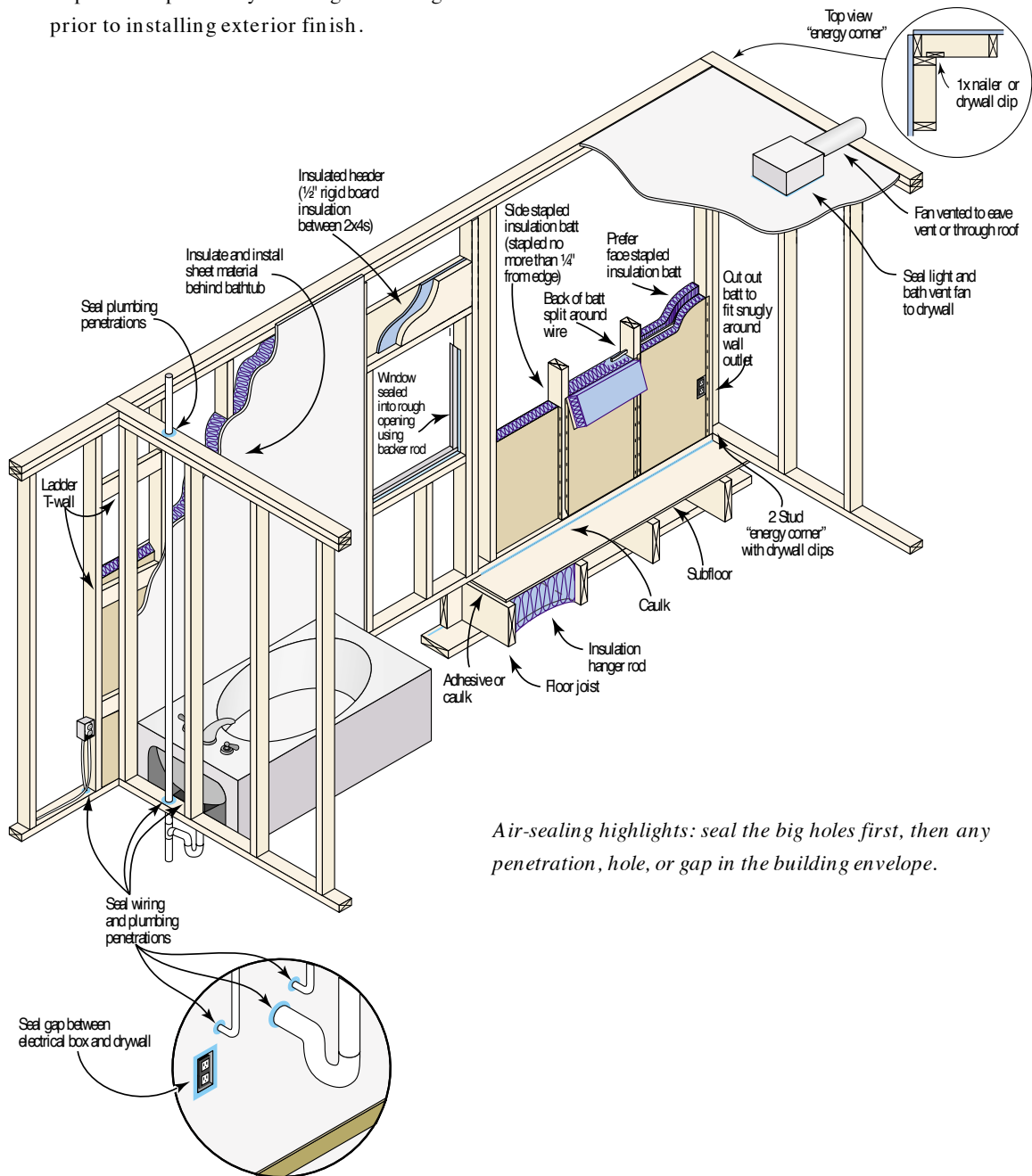

*Air-sealing highlights: seal the big holes first, then any penetration, hole, or gap in the building envelope.*

---

## Reducing HVAC Equipment and Utility Costs with Air-Sealing

Reducing infiltration can cut monthly heating and cooling costs significantly. Because infiltration can account for more than 50% of heating loads and a significant part of cooling loads, tightening the building can often also decrease the size and initial cost of the HVAC system. Air infiltration is taken into account when a “load calculation” is done to size HVAC equipment. A typical house may be more than twice as leaky as an energy-efficient home. Home Energy Raters measure leakiness with a blower door test. This test measures a home’s air tightness in air changes per hour (ACH). Under a test pressure of 50 pascals, an average house has 12 ACH, while a better home has 6 ACH or fewer. Savings for a 2,600-square-foot home can be more than \$170 per year.

Typical Blower Door Setup

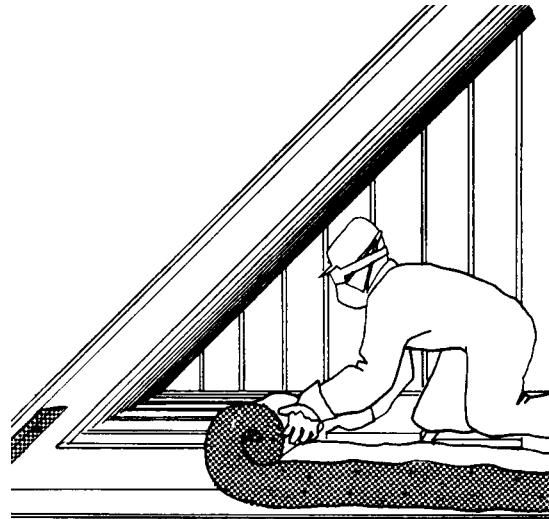
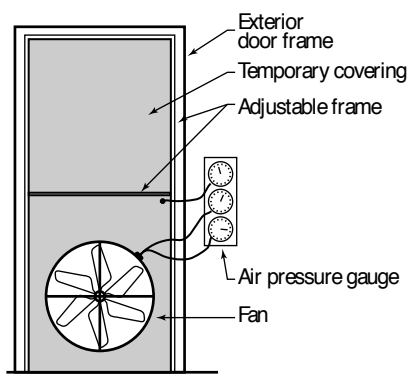

---

## Practice 2

### Create a Continuous Insulation Barrier

---

#### Why this practice is important

Insulation reduces heat flow through the building envelope. Gaps in insulation waste energy and can lead to condensation that can damage building materials and cause growth of molds, dust mites, and other biological contaminants.

The effectiveness of insulation is measured by its R-value—the resistance to heat flow. The higher the R-value, the greater the insulating value. The recommended amount of insulation depends on the building design, the climate, the price of energy, and the cost of materials and labor. Consult the Model Energy Code (MEC) for minimum insulation levels; any construction project using federal dollars must comply with the MEC.

It is usually cost-effective to exceed the minimum insulation levels set by the MEC. An ENERGY STAR home exceeds the MEC by 30% and provides benefits to both builder and homebuyer.

## The solution and its benefits

While the amount of insulation installed is important, so is the quality of installation. Even small gaps and compressed areas can reduce insulating levels significantly. A study of attic insulation found that voids of just 5% in the insulation—typical in many homes—could reduce the overall R-value by more than 30%.

It is important to seal air leaks before insulating. Commonly used insulation materials, such as batt and loose-fill products, do not stop air leakage. As air leaks through these materials, it lowers the R-value. For most home designs, materials other than insulation will form the air barrier. There are some insulation products, such as rigid foam sheathings and spray-in-place materials, that can reduce air leakage as well as insulate.

### Here's What You Can Do

#### ✓ Install insulation properly.

Ensure that there are no voids in the insulation barrier and that materials are installed according to manufacturers' specifications.

#### ✓ Don't skimp when specifying R-values.

- Ceilings to at least R-30 (consider R-38)
- Knee walls to at least R-19 for stud cavities and with insulated sheathing
- Wall cavities and sheathing to at least R-16 (consider R-24)
- Floors to R-19
- Heated basement walls to R-10
- Slab-on-grade to R-5 (provide termite protection)

#### ✓ Seal all penetrations prior to insulation.

Most insulation materials do not block air leakage. Use foam spray, caulks, and foam backer rod to fill all penetrations made for electrical, plumbing, and HVAC systems before installing insulation. Pay special attention to closing off

bypasses in the floor and ceiling, such as around chimneys, closets, tray ceilings, tub drains, recessed lights, and sanitary vent stacks. Use foam board and caulk to seal around large, non-heat-producing areas. Use metal and temperature-rated caulk to seal around combustion vents.

#### ✓ Specify unfaced fiberglass batts or blown-in insulation.

The key is filling the entire cavity with insulation. Unfaced batts prevent voids created by penetrations into side-stapled batts. Blown-in products are more expensive but fill voids completely and are often excellent air barriers.

#### ✓ Specify energy-efficient "advanced wall framing."

Reducing the quantity of wood in framing increases space for extra insulation and reduces framing costs. Consider the following:

- Framed energy corners
- Partition wall connectors such as ladder T's, 2x6s "on the flat," or drywall clips
- Insulated headers or no headers under non-load-bearing gable end walls
- 24-inch stud spacing with 2x4s for houses up to 1½ stories (or 2x6s allowing R-22 batts)
- Metal hangers instead of jack studs
- In-line framing allowing single top-plates (adjust stud length to accommodate drywall)
- Windows designed for 22½-inch or 46½-inch rough openings (fits 24-inch stud spacing)
- Let-in bracing or metal bracing to permit full insulated sheathing on exterior

#### ✓ Consider advanced technologies.

Three advanced thermal envelope technologies that are already available are structural insulated panels, insulated concrete forms, and autoclaved aerated concrete blocks.

- *Structural insulated panels (SIPs)*  
SIPs are made of foam insulation sandwiched between two layers of plywood or OSB. While

material costs typically run 10 to 20% higher than costs for conventional framing, actual installation time can be cut in half. SIPs usually offer energy savings of 10 to 30% above conventional framing because of their higher insulating value and airtight construction. SIPs construction also reduce the amount of wood in the framing by 10 to 30%.

- *Insulated concrete forms (ICFs)*  
ICFs are made of foam insulation that is joined by plastic snaps, steel straps, or other means. When concrete is poured into these forms, the result is a strong wall system with an R-value of between R-16 and R-24, depending on foam thickness. An additional benefit of ICFs is the thermal mass of the concrete, which reduces temperature swings between outside and inside air temperatures. ICFs below grade must address termites and moisture.



#### **SIPs Used at the Southface Energy and Environmental Resource Center**

*The above-grade walls and roof of Southface in Atlanta, Georgia, were constructed with SIPs. The panels, ranging in size from 4 × 8 to 4 × 22 feet, form an airtight envelope with continuous insulation and are stronger than conventional stick framing. They contain no CFCs, HCFCs, HFCs, or formaldehyde, and are fire-rated and recognized by all national building codes.*

- *Autoclaved aerated concrete blocks*  
Autoclaved aerated concrete blocks are made of concrete with air introduced during manufacturing. An 8-inch block has an R-value comparable to that of a framed wall. However, the wall is extremely tight and avoids the insulation voids common in framed construction. In addition, the mass of the wall provides additional thermal benefits. These blocks are laid similar to the way that concrete masonry units are, and they can be easily cut and nailed. The finished wall system should be sealed to prevent water absorption.

In addition to these currently available advanced products, other promising alternatives are being perfected. Among these are steel framing and straw-bale construction.

- *Steel framing*  
Many builders are turning to metal studs because of dissatisfaction with the quality of wood studs and the significant advantages of the lightweight, easy-to-handle metal units. However, because of the high thermal conductivity of metal, an inch of foam insulation must be placed on the exterior of metal walls, and the underside of metal joists must be covered with foam before drywall is attached. Metal studs also have pre-cut openings that can contribute to excessive air leakage unless thoroughly sealed.

- *Straw-bale walls*  
There has been considerable interest around the country in straw-bale construction because it is a renewable technology. Walls in straw-bale houses typically are made of 16- to 30-inch-thick compressed straw. The R-values of straw-bale walls are under study. The major disadvantages to using straw-bale construction include the extra size of the footprint required due to its thickness, structural considerations that must be addressed to ensure safe construction, moisture concerns, and restrictions on finish materials.

## Specify Properly Sized, High-Efficiency HVAC Equipment

### Why this practice is important

Poor design and installation of HVAC equipment commonly increases energy costs 10 to 30%. This practice wastes money and can endanger the health of families. Proper design and installation of HVAC equipment is usually the top priority for cutting energy bills. Equipment that is too big (excess capacity) costs more to buy and operate, and leads to poor comfort, humidity problems, excess noise, and greater pollution.

In fact, oversizing is perhaps the most serious mistake made. Do not allow rules of thumb, such as so much heating or cooling per square foot of living area, to be used to determine equipment size. To size equipment, require exact calculations that consider insulation levels, window type and orientation, and air-sealing measures. Calculating equipment size should take less than an hour for most home designs, will prevent the purchase of costly, oversized equipment, and will provide significant savings to homeowners for years to come.

### The solution and its benefits

High-efficiency heating and cooling equipment can cut energy costs substantially. For example, in a mixed climate like that in most of the Southeast, choosing a central air conditioning unit that has a seasonal energy efficiency ratio (SEER) of 13 instead of SEER 10 costs about \$650 extra but saves at least \$135 a year, for a 25% rate of return on the investment. The added monthly mortgage cost is around \$5, while it saves \$11 a

month (averaged for the entire year) in energy costs. Additional savings can be achieved by specifying more advanced systems, such as geothermal heat pumps or condensing gas furnaces.

### HVAC Equipment Efficiency

*High-efficiency equipment costs more than standard models; reducing equipment size through energy improvements to the building envelope offsets this extra cost. Three important measures of efficiency:*

- **AFUE** (annual fuel utilization efficiency)—measures the efficiency of furnaces. Units range from a low AFUE of 78% to a mid-range of 80 to 82% to a high efficiency of 90 to 95%. It is important to note that AFUE does not measure the electrical consumption of the furnace blower. An inefficient blower can waste hundreds of dollars over its life. Use the manufacturer's data sheets to compare blower efficiency as well as AFUE.
- **HSPF** (heating season performance factor)—measures the efficiency of an electric heat pump in heating mode. Units range from a low HSPF of 6.8 to a mid-range of 7.2 to a high efficiency of 8.0.
- **SEER** (seasonal energy efficiency ratio)—measures the cooling efficiency of an air conditioner or heat pump. Units range from a low SEER of 10 to a mid-range of 12 to a high efficiency of over 14.

## Here's What You Can Do

Proper installation of HVAC is critical to its performance. Here are a few tips to keep in mind when choosing and installing equipment:

- ✓ Select an HVAC contractor who emphasizes correct equipment sizing.

Make sure to specify that the HVAC contractor will size equipment by the American Society of Heating, Refrigerating, and Air-Conditioning Engineers (ASHRAE) techniques or the Air Conditioning Contractors of America's (ACCA's) *Manual J*. Inform the contractor of special energy features, such as superior airtightness, insulation levels, passive solar heating, and smart location of windows. Ask to see the calculation sheet used.

The professional who calculates the size of the HVAC equipment should be able to determine estimated operating costs for various energy sources. While future prices can vary, it is important to consider the cost of energy sources when selecting equipment. Saving a few dollars on equipment is no bargain if families will pay hundreds more because the equipment uses an expensive energy source.

- ✓ Choose high-efficiency cooling equipment.

In general, specify cooling efficiency of at least 2 SEER above code minimum. Keep in mind that the more energy efficient the home is built, the less advantage to higher-performance equipment. Typically, medium-efficiency equipment (12 to 14 SEER) is sufficient for energy-efficient homes.

- ✓ Consider furnace efficiency and venting.

Specify a minimum furnace efficiency of 80% AFUE; consider 90% AFUE furnaces. Do not rely on room air for combustion or venting. Isolate furnaces from conditioned space or use sealed-combustion, direct-vent units.

- ✓ For heat pumps, consider one of the following options to ensure economy and comfort during the heating season:

- Specify a heat pump with an HSPF above 7.2.
- Make sure the heat pump has an outdoor thermostat that prevents electric strip heaters from operating when outside air temperature is above 40°F.
- Consider ground-source heat pumps in areas that are regularly exposed to outside air temperature below 30°F or for houses with high heating bills.

- ✓ If the home is energy-efficient (with 0.35 “natural” ACH or less, high R-value envelope and windows) consider the following specifications:

- Insist on smaller HVAC equipment than for a typical home.
- Reduce the cooling equipment sensible heating fraction to below 70% to ensure proper dehumidification.
- Consider a variable-speed compressor for cooling equipment to ensure proper dehumidification and quiet operation.

- ✓ Insist on a high-quality installation of the HVAC equipment.

Before final payment, verify that the equipment has been installed in a secure and accessible manner. Ensure that the system was properly tested. A good HVAC contractor will carefully test refrigerant line pressure and the temperature of delivered air to ensure proper system operation. Too little or too much refrigerant can cause both poor performance and possible damage to the system.

- ✓ Consider other advanced HVAC equipment.
- *Integrated natural gas space and water heaters*  
Because energy-efficient homes require little heating, it is easy to use a water heater both for home heating and to provide domestic hot water. This approach can save on installation costs and requires less floor space. Be sure to specify a high-efficiency water heater.

- *Zoned HVAC systems that can deliver heating or cooling as needed*

Make sure that the price compares favorably to that of separate units. A variable-speed compressor is especially recommended in a zoned system because it can run more slowly when dampers have closed off parts of the house.

- *De-superheaters*  
De-superheater systems capture waste heat from the air conditioner to heat water and are worth considering when only electric water heating is available.
- *Hydronic heating (boilers)*  
Small boilers that can deliver hot water to traditional radiators, baseboard heaters, or even through subflooring are now available. This type of system tends to be expensive but can be useful for clients with respiratory conditions that are worsened by forced-air heating. These boilers are typically used in colder climates where central cooling is less important, thus saving the cost associated with ductwork.

## Practice 4

# Design and Install Ductwork and Filters Properly

### Why this practice is important

Poorly designed and installed duct systems can easily make the most expensive high-efficiency HVAC equipment perform like the worst system on the market. In terms of indoor air quality, leaky ducts literally suck high humidity, dust, mold spores, and other contaminants into a home. Duct systems that are incorrectly balanced cause high and low pressure zones throughout the house, forcing conditioned air outside and unconditioned air into the house. Poorly designed duct systems can also cause discomfort when lower-temperature air blows directly on residents. Up to 30% of heating and cooling costs can be attributed to poorly designed and installed ducts, costing homeowners money and polluting the environment.

Most residential HVAC filters are ineffective at filtering air, and a poorly installed filter cabinet can cause major duct leakage. A low-quality filtration system causes dirt to accumulate on blower fans and heat exchangers, reducing system efficiency, and does little to protect the homeowners from air pollutants.

### The solution and its benefits

Good duct design and installation practices are not difficult; they just require care and follow-up. Virtually no mechanical inspector for a local government has the time or training to see what are usually hidden defects. While a good job done by a reputable contractor may cost \$150 to \$300 more, savings from \$100 to \$500 a year make it a smart investment.

## Here's What You Can Do

The key to getting a well-installed duct system is the quality of the HVAC contractor selected to do the job. Here are a few tips to help get the job done right:

- ✓ Create floor plans with the duct layout and the location of the HVAC unit in mind.

While most HVAC contractors can put a system into just about any floor plan, you can greatly enhance the performance of a system by

- centrally locating the unit and making it easily accessible to installers and service technicians
  - locating ductwork inside the conditioned space
  - placing room vents so as to allow short branches off a central trunk
  - planning chases and other areas for ductwork
- ✓ Ensure that the installer calculates the air volume needs of each room using *ACCA Manual D*.

Absolutely insist that ducts be sized on a careful, room-by-room calculation of the heating and cooling loads throughout the house in accordance with *ACCA Manual D*. A one-size-fits-all approach is a typical yet serious mistake made by many installers.

- ✓ Ask for air return vents throughout the house.

Most home occupants close off parts of their home throughout the day and night. To prevent negative and positive pressure zones in the house, rooms or closeable areas with more than one supply register need a separate return vent. Always ensure that interior doors have 1 inch of clearance to the floor.

- ✓ Locate ducts in the conditioned space.

While this practice is a major step, such a system change can virtually eliminate the substantial energy penalty caused by leaking ducts because any leaks occur inside the conditioned space.

- ✓ Use mastic to seal the entire duct system; test for leaks.

While using mastic for duct sealing is required by the 1995 MEC, many contractors avoid its use. Insist that all duct connections—including boots, elbows, take-offs, plenums, and joints—be thoroughly sealed with fiberglass mesh tape and mastic. Pressure-test ducts to ensure airtightness.

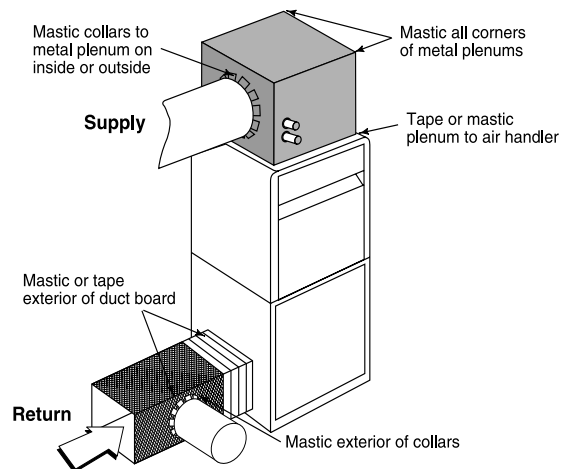

*Seal all joints in the air handler and the duct system with mastic.*

- ✓ Pressure-balance the system.

Using a flowmeter, an HVAC contractor can test the amount of air delivered to each room. This test is the only way to ensure that the designed air flow is actually getting to each of the rooms. Require that the contractor prove proper air flow before final payment. If testing is not possible, ensure that ducts are not pinched or restricted.



- ✓ Insulate ductwork.

Ductwork often passes through attics that can reach 140° F. Use R-6 or better duct insulation in all unconditioned spaces.

- ✓ Upgrade filtration.

Specify a filter with a minimum atmospheric-dust-spot efficiency rating of 15%. Offer homebuyers upgrades for pleated media filters and electronic air cleaners with dust-spot efficiencies of 40 to 90%. Ensure that filter cabinets are airtight.

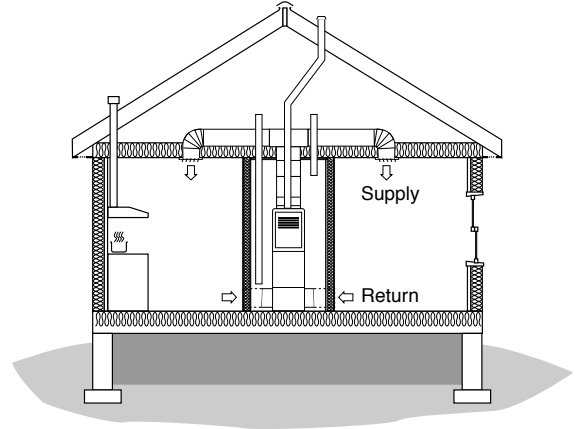

*A well-balanced HVAC system combined with proper spot ventilation in kitchens and baths, plus appropriate isolation and venting of combustion appliances, all ensure good indoor air quality in the home.*

## Practice 5

# Prevent Interior Moisture Buildup with Controlled Ventilation

## Why this practice is important

Today's homes need controlled ventilation. Every day, bathrooms and kitchens release water vapor and odors into indoor air, which can lead to mold, mildew, and other allergens indoors. In some cases, the high relative humidity levels caused by inadequate ventilation can cause building materials to deteriorate.

Relying on cracks in the building envelope to provide proper ventilation is ineffective and endangers health and safety. For most home designs, simple, controlled ventilation systems can be economical to install and operate. In temperate climates, many builders rely on upgraded bath fans and kitchen range hoods ducted to the outside. Whole-house ventilation, including options for humidity control and heat recovery, can enhance comfort and air quality.

## The solution and its benefits

The amount of ventilation required varies according to the home design and occupant activities that cause stale room air. Typically, the ventilation rate is based on preventing moisture buildup. When excess moisture causes relative humidity to rise above 50%, mold and dust mites thrive.

The ideal range of relative humidity year round is between 30 and 50%. To help maintain this constant level, install high-quality vent fans in baths and kitchens that are properly vented to the outside. Higher-quality fans move more air and are much quieter than standard models.

Effective spot ventilation is the minimum approach needed for homes in the Southeast. Whole-house ventilation can provide continuous fresh air throughout the house and is often combined with filtration or humidity control.

## Here's What You Can Do

When specifying kitchen and bath ventilation equipment keep the following tips in mind:

- ✓ Specify fans that are matched to the size of the room being ventilated.

A typical bathroom needs to remove at least 50 cubic feet per minute (cfm) of air; kitchens need 100 cfm.

- ✓ Select fans that are efficient and quiet to encourage their regular use.

Sound levels are rated in sones. Choose bath fans that are rated at 1.5 sones or lower. Select energy-efficient fans that run on less than 40 watts.

- ✓ Specify venting that is not resistant to air flow.

Fan size ratings assume straight ducting with few bends. Call for smooth-walled piping that is appropriately sized, has minimal turns, and has the shortest possible run to the outside. Bends in vent ducts can reduce capacity more than 30%.

- ✓ Vent all fans to the outside.

Do not terminate bath fans in attics. Do not install recirculating kitchen range hoods. Ensure that clothes dryers vent to the outdoors, and that the ducting has few bends.

- ✓ Air-seal fan penetrations to drywall.

## Practice 6

# Specify Energy-Efficient Windows and Doors

### Why this practice is important

Poor-quality windows and doors waste energy and threaten long-term building durability.

Inappropriate locations and window sizing can cause serious energy penalties from overheating in summer or loss of solar heating benefits in winter.

Windows cause energy losses in three ways:

- Air leaks through windows and frames cause convection losses of heated or cooled air. This problem is most noticed with older, leakier windows.
- Less discernible but more significant are losses caused by conduction, where heat passes through solid surfaces such as metal and glass. Many insulated windows fail to perform effectively because they lose so much heat at their edges.
- Heat also moves through windows by radiation, causing heat gain in summer and heat loss in winter.

### The solution and its benefits

Selecting energy-efficient windows and strategically locating windows in the floor plan can provide significant energy savings and greater comfort. Using well-placed, energy-efficient windows can save as much as 30% in energy costs compared to low-quality windows placed indiscriminately. High-efficiency windows on the market today permit greater flexibility in window placement, allowing greater use of glazing on the north side to enhance daylighting. Glazing options permit strategic use

of different light and solar radiation characteristics to further maximize energy efficiency, comfort, and visibility.

Benefits from planning and selecting better windows include

- Lower heating and cooling bills
- Reduction in size of HVAC equipment
- Passive solar heating
- Reduction in “sweating” on windows
- Increased thermal comfort
- Reduced fading of room furnishings
- Daylighting that reduces lighting bills and improves occupant well-being



<b>National Fenestration Rating Council</b> INCORPORATED			
<b>AAA Window Company</b>			
Energy Rating Factors	Ratings		Product Description
	Residential	Nonresidential	
U-factor <small>Determined in accordance with NFRC 100</small>	0.40	0.38	Model 1000 Casement Low-e Argon Filled
Solar Heat Gain Coefficient <small>Determined in accordance with NFRC 200</small>	0.65	0.66	
Visible Transmittance <small>Determined in accordance with NFRC 200</small>	0.71	0.71	
<small>NFRC ratings are determined for a fixed set of environmental conditions and specific product sizes and may not be appropriate for directly determining seasonal energy performance. For additional information contact:</small>			

Look for the National Fenestration Rating Council (NFRC) label when purchasing a window. Use the formula  $R = 1/U$ -factor to determine the R-value from an NFRC label.

## Here's What You Can Do

The following tips should help make the most of your window budget and meet the overall goals of an energy-efficient, sustainable building:

- ✓ Choose windows with an “overall average” R-value of at least 1.7.

Not all insulated windows meet this minimum. Metal windows comply only when thermally broken at their edges. Be sure windows have been rated by the National Fenestration Rating Council (NFRC) or another reputable rating or testing program.

- ✓ Choose windows that are designed to be airtight.

Double-hung windows should leak no more than 0.25 cfm per linear foot of sash opening.

Casement windows should not leak more than 0.10 cfm per linear foot of sash opening.

- ✓ Reduce glass area and solar radiation on west- and east-facing walls.

West-facing windows should be eliminated or completely shaded. East-facing windows should be limited or completely shaded. Otherwise, for both west- and east-facing walls, limit window glass area and select units with a low solar heat gain coefficient (below 50%).

- ✓ Increase the glass area and energy efficiency of south- and north-facing windows.

Maximize glass area on the south as long as shading is provided for summer. More windows can be used for natural lighting on the north side if you specify low-E and inert gas-filled glazing.

## Practice 7

# Install Energy-Efficient Water Heating

### Why this practice is important

Energy used to heat water for homes can rival annual HVAC costs. Electric or propane water heating for a family of four in the South typically costs more than \$400 annually. Costs are about half that amount with natural gas water heaters. Sustainable building design reduces the energy needed to heat water. Many measures also reduce the amount of water wasted in a home and increase the hot water available to the household.

### The solution and its benefits

Choose the least polluting and most economical energy source to heat water. Proper fuel choice can cut energy costs by more than 50%. Efficiency measures can increase savings.

## What You Can Do About It

The following efficiency measures save water and energy:

- ✓ Install high-quality, low-flow shower heads in all baths.
- ✓ Specify water-saving dishwashers and clothes washers. These units are usually quieter than standard models.
- ✓ Use other options that lead to greater savings.
  - *Heat recovery units*  
Also known as de-superheaters, these units capture the waste heat produced during summer air conditioning to heat water. Consider these as add-ons to electric water heaters.
  - *Heat pump water heaters*  
These units are about twice as efficient as standard electric water heaters and cost about four times as much. Annual savings range from \$100 to \$200. These units must be installed where the cold air blowing out will not cause a problem during winter and where winter temperatures will not drop below 45°F. A basement is an ideal location because the unit will provide some dehumidification.
  - *Solar hot water heaters*  
Solar water heaters can provide up to 70% of a family's hot water needs. Solar-heated water is either stored in a separate storage tank or sent to a conventional water heater used as a backup system. Solar water heaters typically cost between \$1,500 and \$5,500 and are particularly attractive to complement an electric water heater and for houses "off the grid."
- ✓ Plan the layout of kitchens and baths to minimize the length of hot water pipes.
- ✓ Lower the temperature setting on water heaters to 120°F.
- ✓ Wrap water heaters with an insulation jacket (may not be needed for some high-efficiency units).
- ✓ Insulate the first 4 feet of hot and cold pipes connected to water heaters or install check valves.

## Design Energy-Efficient Lighting

### Why this practice is important

The only other appliances that use more energy in our homes than lighting are the refrigerator and electric water heater. Homeowners must replace cheap incandescent bulbs so often that grocery stores sell them beside the toothpaste; each year these bulbs cost homeowners around \$3 billion more than efficient lighting and add nearly 42 million tons of carbon dioxide to the atmosphere.

### The solution and its benefits

In the past, many people associated energy-efficient lighting with delayed turn-on, high initial cost, and poor light quality. Today, there are better light bulbs, fixtures, and controls on the market than ever before. Investment in advanced lighting usually pays for itself in less than 5 years. The average savings from energy-efficient lighting is around \$50 a year, depending on house size and lighting use rates. More efficient lighting in a new home generates about 1,000 lb less carbon dioxide each year at the local power plant.

Another huge advantage of energy-efficient lights is that they last around 10 times longer, saving homeowners, especially the elderly, lots of time and hassle over the years. Energy-efficient lighting is a highly visible sign of any green building program.

### What's New in Energy-Efficient Lights

*Compact fluorescent lamps (CFLs) are better than ever today. Four times more energy-efficient than standard bulbs, they also last 9 to 13 times longer. New electronically ballasted fixtures turn on instantly, and at 20,000 cycles per second, do not cause the kind of headaches or eye fatigue often associated with old-style fluorescent tubes that cycled on and off at 60 cycles per second. In addition, new CFLs are much closer to natural light (with a high color-rendering index, or CRI).*



*Earth Light Dimmable CFL, introduced by Philips, was selected by Popular Science as one of the best new products of the year. This bulb can be placed in a standard light fixture with a dimmer control. The bulb, costing around \$20, is dimmable from 10 to 100%.*



*CFLs now come in a multitude of shapes and styles and can work as bare bulbs as well as in various fixtures. CFLs come in either integral or modular types depending on whether the ballast is permanently attached to the bulb or in a separate fixture. Modular CFL fixtures are more expensive to purchase initially, but the replacement cost for each bulb is much less than for integral types, around \$3 to \$5.*

## What You Can Do About It

The following tips will keep your home design on the right track from a cost and quality perspective when specifying energy-efficient lighting:

- ✓ Hire a lighting engineer to evaluate your typical floor plans.

Once you have arrived at a good basic lighting design template for your typical floor plans, you can specify more advanced lighting options in all of your homes. The added cost can be spread over many homes and the formula adjusted for different ambient light conditions.

- ✓ Specify energy-efficient lighting especially for areas of high continuous lighting use.

To maximize energy-efficient lighting gains, spend the most on areas such as the kitchen, workspaces, sitting and reading areas, and outside the home for safety and security. To ensure long-term energy savings, install modular CFL fixtures that only use CFL lamps. Homeowners aren't tempted to switch back to incandescent bulbs, and the cost of replacing modular lamps is much less than that of replacing an integral CFL unit.

- ✓ Focus attention on task and accent lighting design.

Because light levels diminish significantly the farther one is from the source (there is a 75% drop in lighting levels for each doubling in distance), placing lighting closer to where the work will be performed is key. The highest light levels should be reserved for desks, kitchen counters, reading areas, and shop space. Also, by selecting walls, mantels, and other likely display areas for accent lighting, less overall light needs to be provided to a room.

- ✓ Specify only airtight, recessed can lights that can be fully insulated.

Recessed can lights are big energy losers that leak air and require breaks in attic insulation. Specify

only airtight, IC-rated recessed lighting fixtures that meet the ASTM E283 air leakage rating.

- ✓ Put dimmers on all incandescent lights.

Dimming lights can save lots of money, extend bulb life, and provide "as needed" light levels. A typical incandescent light dimmed 50% will save 30% in energy cost and last up to 20 times longer.

- ✓ Install motion sensors, timers, or "photo cells" on exterior lighting.

Exterior lights need not burn during the day. Install high-quality control devices depending on the intended use and location of exterior lighting.

- ✓ Consider innovative control devices for interior lighting.

Often used in commercial settings, occupancy sensors can light rooms on demand as a person enters and uses the space. Lights turn off after an adjustable time period. Sophisticated light sensing controls are now available that dim lights in conjunction with the amount of daylight entering a room.

- ✓ Avoid halogen fixtures.

Although halogens produce a lot of light, their intense heat output poses a fire hazard and places a strain on cooling equipment.

---

*New lights appearing on the market include sulfur microwave lamps and ceramic metal halide lights.*

*They offer extremely long life spans and even lower operating costs than fluorescent lights. The lighting market, like computers, is continuously providing better and cheaper products.*

---

## Specify High-Quality, Water-Saving Faucets and Fixtures

### Why this practice is important

Providing clean water to American households has costly environmental consequences. Families use between 68,000 and 112,000 gallons of water per year just for indoor use. While the cost of the water is marginal—around \$200 a year—a tremendous amount of energy and money goes into water treatment, storing and pumping, and building and maintaining facilities and dams. While saving water in homes has become easier because federal regulations now mandate low-water-use fixtures, builder model equipment often does not perform as intended. In addition to water being wasted, homeowners are unhappy with the performance of the products and may seek to replace or modify equipment with less efficient models.

### The solution and its benefits

The primary benefit comes from specifying water-saving fixtures that perform well and conserve water. Builders typically spend less than \$100 for a toilet, but cheaper models often fail to get the job done and are often flushed multiple times after one use or cause frequent frustration from stop-ups. Better-quality low-flow toilets feature a redesigned geometry that outperforms even older high-water-use models. High-quality shower heads provide a comfortable shower and save considerable water too. Spending a little more up front on water-saving fixtures will bring quality that ensures water-savings and happier homeowners.

The following tips will help you find the best products for the money:

- ✓ Specify higher-quality gravity tank toilets.

Make sure the manufacturer stands by the quality of the flush. A good toilet has been completely redesigned to ensure good flush performance at the 1.6 gallons per flush limit.
- ✓ Consider pressurized-tank toilets.

If pressure at the toilet is at least 25 psi, these commercial type toilets do an excellent job with less water. No plunging is needed.
- ✓ Consider dual-flush-lever toilets.

Some models maximize water efficiency by allowing the user to select a 1.1-gallon flush option for liquid or light waste.
- ✓ Specify high-quality shower heads.

While all shower heads are limited to 2.5 gallons per minute by federal law, choosing a quality product will reduce callbacks and also save water. Quality shower heads rinse better and shorten the time needed in the shower.
- ✓ Consider a hot water “on-demand” circulating system.

For large homes where the water heater is not centrally located, water and energy are wasted down the drain when occupants must let the hot water “run” to get warm. An on-demand circulating system shunts the cooled water in the hot water piping back to the water heater. A switch at the faucet activates a small pump that circulates the water.

## Practice 10

# Specify Energy-Efficient Refrigerators and Appliances

### Why this practice is important

The amount of power used annually to keep food fresh in homes and businesses equals the output of 37 major power plants. Costing about \$50 a year to run, the refrigerator is the third largest power user after space conditioning and water heating in homes. Most refrigerators in use today will cost two to three times their purchase price

in total energy costs over their life. All other appliances use another \$300 per year. Builders rarely focus on energy efficiency when selecting appliances and thus contribute indirectly to a huge national energy waste and air pollution problem.

### The solution and its benefits

While builders do not control all appliances in houses, they do select some key ones. By choosing refrigerators, dishwashers, and other built-ins that reduce energy consumption, and by highlighting those choices in marketing and promotional material emphasizing the builder's commitment to the environment, a builder can also influence homeowners to think more carefully about their own appliance purchase decisions.

**Typical Energy Costs for Appliances**

Appliance	Average model (\$/ yr)	High-efficiency model (\$/ yr)	10-year savings for high-efficiency model
Refrigerator (manual defrost)	56	36	\$200
Refrigerator/ freezer (frost free)	96	56	400
Freezer (frost free)	108	60	480
Electric range	48	40	80
Gas range	36	28	80
Electric clothes dryer	56	44	120
Gas clothes dryer	24	20	40
Dishwasher*	56	36	200
Color television	20	8	120

\*Includes cost of water heating.



## What You Can Do About It

Many appliances are available in energy-efficient models. Look for the ENERGY STAR label to find high-efficiency models. The following tips will help you make the right choices for the homes you build:

- ✓ Install more energy-efficient refrigerators.

While all refrigerators today are about twice as efficient as models produced 20 years ago, still greater savings are available on some models compared with other units. Energy-efficient models put out less waste heat so they reduce home cooling costs as well.

Choose models that

- Are at the “efficient” end of the yellow “EnergyGuide” sticker
- Have a power-saving switch that turns off a condensation-prevention heater when not needed
- Use less than 800 kWh on even the largest units (some units use 38% less energy than the federal energy standard)

Consider models without automatic defrost to save even more energy. (A prior homebuyer agreement makes sense.)

- ✓ Install dishwashers that can perform more efficiently.

Efficient dishwashers save energy and water, and are quiet. Consider these features:

- Units that have a booster water heater
- Units that have light, medium, and heavy cycle options
- Units with an energy-saving “air dry” or “no-heat dry” switch

- ✓ Install efficient appliances in the model home to encourage homebuyers.

Encourage better homeowner choices by installing highly efficient appliances in the model home, and make buying these appliances easy for homebuyers by providing consumer information. The following appliances are best:

- *Horizontal-axis washing machines*  
These front-loading machines use one-half to one-third the energy of standard washers because they use far less water. Additional savings include around \$10 less water and \$35 less detergent used a year. In addition, clothes are cleaned better; and because these units spin clothes much dryer, energy is also saved during drying.
- *Dryers that feature energy-saving switches and humidity detectors*
- *Gas stoves or electric ranges with induction elements*
- *Convection ovens*  
Convection ovens are about one-third more efficient than standard ovens.
- *EPA ENERGY STAR–rated home office equipment*  
More and more homes today include a home office. Encourage selection of energy-efficient equipment.

---

### Energy-Efficient Appliances

*The Southface Energy Institute provides visitors with a hands-on view of the most energy-efficient appliances, including the following:*

- *A side-by-side refrigerator that is 38% more energy efficient than the industry standard*
  - *A front-loading, horizontal-axis clothes washer. The water level is automatically adjusted to the size of the load. Total savings can amount to 8,000 gallons of water annually.*
  - *A 27-inch ENERGY STAR TV using a darker screen to combat competing ambient light and using less than 100 watts of power*
  - *Copiers and computers with ENERGY STAR labels indicating a minimum of 30% better energy performance than the industry standard.*
-



## Appendix A

# Sources and Additional Resources

### Introduction

#### SOURCES

Burchell, Robert W., and David Listokin. *Land, Infrastructure, Housing Costs and Fiscal Impacts Associated with Growth: The Literature on the Impacts of Sprawl Versus Managed Growth*. Cambridge, MA: Lincoln Institute of Land Policy, 1995.

### Chapter 1: Sustainable Land Use Planning

#### Introduction

#### SOURCES

Lend Lease Real Estate Investment Co. *Emerging Trends in Real Estate '99*.  
<http://www.lendleaserei.com/LLREI/FreeForm.nsf/wcontent> (select document EMGT0).

Sorensen, A. Ann, Richard P. Greene, and Karen Russ. *Farming on the Edge*. Washington, DC: American Farmland Trust, 1997.

#### Practice 1: Preserve Open Space and Create More Compact Communities

#### SOURCES

Alexander, Christopher. *A Pattern Language: Towns, Buildings, Construction*. Oxford: Oxford University Press, 1977.

*The Energy Yardstick: Using PLACE<sup>3</sup>S to Create More Sustainable Communities*. Denver, CO: Center of Excellence for Sustainable Development, June 1996. (800) 363-3732  
<http://www.sustainable.doe.gov/pdf/places.pdf>

#### ADDITIONAL RESOURCES

Logothetti, Sheena, Elizabeth Davis, and Monica Stucky. *Conservation Subdivisions: Designing for Open Space in Cherokee County*. Athens, GA: Etowah Initiative, School of Law and Institute of Ecology,

University of Georgia, April 1998.

Bledsoe, Melissa, Joe Covert, William Jones, and Autumn Rierson. *The Potential for Transferable Development Rights in Cherokee County*. Athens, GA: Etowah Initiative, School of Law and Institute of Ecology, University of Georgia, January 1998.

Fowler, Laurie, and Hans Neuhauser. *A Landowner's Guide: Conservation Easements for Natural Resource Protection*. Atlanta, GA: Georgia Department of Natural Resources, 1998.

American Farmland Trust  
1200 18th Street NW, Suite 800  
Washington, DC 20036  
(202) 331-7300  
<http://www.farmland.org>

Congress for the New Urbanism  
The Hearst Building  
5 Third Street, Suite 500A  
San Francisco, CA 94103  
(415) 495-2255  
<http://www.cnu.org>

The Nature Conservancy  
International Headquarters  
1815 North Lynn Street  
Arlington, VA 22209  
(703) 841-5300  
<http://www.tnc.org>

Traditional Neighborhood Development Ordinance  
Belmont, NC  
<http://www.ci.belmont-nc.us/Belmont/tnd.htm>

Transfer of Development Rights Information  
<http://farm.fic.niu.edu/fic-ta/tafs-tdr.html>

#### Practice 2: Create Mixed-Use, Walkable Communities

#### SOURCES

Katz, Peter. *The New Urbanism*. New York: McGraw-Hill, 1994.

Langdon, Philip. *A Better Place to Live*. New York: Harper Perennial, 1994.

**ADDITIONAL RESOURCES**

Walkable Communities, Inc.  
320 S. Main Street  
High Springs, FL 32643  
(904) 454-3304  
<http://www.walkable.org>

### **Practice 3: Encourage Environmentally Based Land Use Plans and Walkable Community Zoning Ordinances**

**ADDITIONAL RESOURCES**

Porter, Douglas R., Patrick L. Phillips, and Terry J. Lassar. *Flexible Zoning: How it Works*. Washington, DC: The Urban Land Institute, 1988.

### **Practice 4: Encourage Urban In-fill and Brownfield Redevelopment**

**ADDITIONAL RESOURCES**

Simons, Robert A. *Turning Brownfields into Greenbacks*. Washington, DC: Urban Land Institute, 1997.

US Environmental Protection Agency  
Region 4  
Atlanta Federal Center  
61 Forsyth Street SW  
Atlanta, GA 30303-3104  
Main Switchboard (404) 562-9900  
Brownfields Initiative (404) 562-8923  
<http://www.epa.gov/region4>

### **Practice 5: Create Sustainable Master-Planned Communities**

**SOURCES**

Hawken, Paul. *The Ecology of Commerce*. New York: Harper Business, 1993

**ADDITIONAL RESOURCES**

Celebration, Florida  
The Celebration Company  
610 Sycamore Street, Suite 310  
Celebration, FL 34747  
(407) 566-2200  
<http://www.abfla.com/1tocf/disney/celeb.html>

Kentlands, Maryland  
Kentlands Club  
485 Tschiffely Square Road  
Gaithersburg, MD 20878  
<http://www.his.com/~hkay/kcca1.html>

Seaside, Florida  
Seaside  
P.O. Box 4730  
County Road 30-A  
Seaside, FL 32459  
(800) 277-8696  
<http://www.seaside-fl.com>

### **Practice 6: Develop a Smart Growth Plan for Your Community**

**SOURCES**

*The Energy Yardstick: Using PLACE<sup>3</sup>S to Create More Sustainable Communities*. Denver, CO: Center of Excellence for Sustainable Development, June 1996.  
(800) 363-3732  
<http://www.sustainable.doe.gov/pdf/places.pdf>

**ADDITIONAL RESOURCES**

Center of Excellence for Sustainable Development  
U.S. Department of Energy  
Office of Energy Efficiency and Renewable Energy  
Denver Regional Support Office  
1617 Cole Boulevard  
Golden, CO 80401  
(800) 363-3732  
<http://www.sustainable.doe.gov>  
[sustainable.development@hq.doe.gov](mailto:sustainable.development@hq.doe.gov)

Smart Growth Network  
777 North Capitol Street NE, Suite 500  
Washington, DC 20002-4201  
(202) 962-3591  
<http://www.smartgrowth.org>

*The following resources pertain to several of the practices discussed in Chapter 1.*

**ADDITIONAL RESOURCES**

Ausubel, Kenny. *Restoring the Earth*. Tiburon, CA: HJ Kramer, 1997.

Barnett, Jonathan. *The Fractured Metropolis*. New York: Icon Editions, 1995

Diamond, Henry L., and Patrick F. Noonan. *Land Use in America*. Washington, DC: Island Press, 1996.

Ewing, Reid. *Best Development Practices*. Chicago: Planners Press, 1996.

Kelbaugh, Douglas. *Common Place*. Seattle: University of Washington Press, 1997.

Kunstler, James. *The Geography of Nowhere*. New York: Simon & Schuster, 1993.

Kunstler, James. *Home from Nowhere*. New York: Simon & Schuster, 1996.

Norwood, Ken and Kathleen Smith. *Rebuilding Community in America*. Berkeley, CA: Shared Living Resource Center, 1995.

Democracy Place, USA  
<http://democracyplace.org>

*Planning Commissioners Journal*  
<http://www.plannersweb.com>

The Urban Land Institute  
1025 Thomas Jefferson Street NW, Suite 500W  
Washington DC 20007-5201  
(202) 624-7000  
<http://www.uli.org>

## Chapter 2: Sustainable Site Development

---

### Practice 1: Create Subdivisions That Preserve Open Space

#### SOURCES

Arendt, Randall. *Conservation Design for Subdivisions: A Practical Guide to Creating Open Space Networks*. Washington, DC: Island Press, 1996.

Ewing, Reid. *Best Development Practices*. Chicago: Planners Press, 1996.

*The Energy Yardstick: Using PLACE<sup>3</sup>S to Create More Sustainable Communities*. Denver, CO: Center of Excellence for Sustainable Development, June 1996. (800) 363-3732  
<http://www.sustainable.doe.gov/pdf/places.pdf>

#### ADDITIONAL RESOURCES

The Center for Rural Massachusetts  
University of Massachusetts  
109 Hills North  
Amherst, MA 01003  
(413) 545-2612  
Email: [ruralma@larp.umass.edu](mailto:ruralma@larp.umass.edu)

Natural Lands Trust  
Hildacy Farm  
1031 Palmers Mill Road  
Media, PA 19063  
(610) 353-5587  
<http://www.natlands.org>

### Practice 2: Survey and Consider the Environmental Features of Your Site

#### SOURCES

McCurdy, Jim. "Backyard Wildlife Habitat." *Southface Journal*, no. 1 (1996): 5-6.

The School of Environmental Design at University of Georgia. *Land Development Provisions to Protect Georgia Water Quality*. Atlanta: Georgia Department of Natural Resources, Environmental Protection Division, October 1997.

Wilson, Alex. "Getting to Know a Place: Site Evaluation as a Starting Point for Green Design." *Environmental Building News* 7, no. 3 (March 1998): 1, 8-14.

#### ADDITIONAL RESOURCES

McHarg, Ian L. *Design with Nature*. 2nd edition. New York: John Wiley and Sons, 1995.

Georgia Soil and Water Conservation Commission  
4310 Lexington Road  
Athens, GA 30605  
(706) 524-3065

Natural Resource Conservation Service  
(formerly Soil and Water Conservation Service)  
Southeast Regional Office  
1720 Peachtree Road NW, Suite 446 N  
Atlanta, GA 30309-2439  
(404) 347-6105  
<http://www.nrsc.gov>

U.S. Geological Survey  
Earth Science Information Center  
(800) USA-MAPS

U.S. Geological Survey-Alabama  
2350 Fairlane Drive, Suite 120  
Montgomery, AL 36116  
(334) 213-2332

U.S. Geological Survey-Georgia  
Peachtree Business Center, Suite 130  
3039 Amwiler Road  
Atlanta, GA 30360-2824  
(770) 903-9100  
<http://www.usgs.gov>

### Practice 3: Minimize Soil Disturbance and Compaction during Construction

#### SOURCES

Build Green and Profit series. Gainesville, FL:  
University of Florida, Florida Energy Extension  
Service, 1998. (352) 392-8074.

#### ADDITIONAL RESOURCES

*Sustainable Building Technical Manual: Green Building Design, Construction, and Operations*. Washington, DC: Public Technology, 1996.

Public Technology, Inc.  
1301 Pennsylvania Ave. NW  
Washington, DC 20004-1793  
(800) 852-4934

### Practice 4: Control Erosion and Sedimentation during Construction

#### SOURCES

Price-Robinson, Kathy. "Hold on to Your Dirt." *Journal of Light Construction* 16, no. 8 (June 1998): 15-18.

*Water Resources of the Atlanta Region* (map). Atlanta: Atlanta Regional Commission. (404) 364-2502

#### ADDITIONAL RESOURCES

Brown, Whitney, and Deborah Caraco. *Muddy Water in—Muddy Water Out? A Critique of Erosion and Sediment Control Plans*. Available at <http://www.pipeline.com/~mrrunoff/mud2.htm>

*Erosion Control*, Official Journal of the International Erosion Control Association. (805) 681-1300

*Erosion + Sediment Control Field Guide*. Atlanta: Upper Chattahoochee Riverkeeper, 1997.

*Manual for Erosion and Sediment Control in Georgia.* 4th edition. Athens, GA: Georgia Soil and Water Conservation Commission. (706) 524-3065

Cawaco RC&D Council, Inc.  
2112 Eleventh Ave. South  
Birmingham, AL 35205-2863  
(205) 251-8139

International Erosion Control Association  
P.O. Box 774904  
Steamboat Springs, CO 80477-4904  
(800) 455-4322  
<http://www.ieca.org>  
[ecinfo@ieca.org](mailto:ecinfo@ieca.org)

Upper Chattahoochee River Keeper  
1900 Emery Street, Suite 450  
Atlanta, GA 30318  
(404) 352-9828  
<http://www.chattahoochee.org>  
[rivrkeep@mindspring.com](mailto:rivrkeep@mindspring.com)

U.S. Army Corps of Engineers  
South Atlantic Division  
(404) 562-5011  
<http://www.sad.usace.army.mil>  
Charleston, SC District Office  
(803) 727-4201  
Jacksonville, FL District Office  
(904) 232-2235  
Mobile, AL District Office  
(334) 690-2505  
Savannah, GA District Office  
(912) 652-5279  
Wilmington, NC District Office  
(910) 251-4626

## Practice 5: Protect Trees during Site Clearing and Construction

### SOURCES

- Ferguson, Bruce K. *Introduction to Stormwater*. New York: John Wiley & Sons, 1998.
- McCurdy, Jim. "Protecting Trees from Construction Damage." *Southface Journal*, no. 2 (1995): 8-10.
- Petit, Jack, Debra L. Bassert, and Cheryl Kollin. *Building Greener Neighborhoods: Trees as Part of the Plan*. Washington, DC: American Forests and Home Builder Press, 1995.
- Wilson, Alex. "Setting Your Sites on Saving Trees." *GoodCents*, January/February 1996, 9-11.

### ADDITIONAL RESOURCES

- Brown, Dennis. "Protecting Trees from Construction." *Environmental Design and Construction*, May/June 1998, 35-36.
- Cooling Our Communities: A Guidebook on Tree Planting and Light-Colored Surfacing*. GPO Document 055-000-00371-8. Washington, DC: U.S. Environmental Protection Agency, January 1992.
- Moll, Gary and Stanley Young. *Growing Greener Cities*. Los Angeles: Living Planet Press, 1992.

Wilson, Alex, and Dan MacArthur. "Protecting Trees and the Immediate Environment during Sitework." *Environmental Building News* 1, no. 4 (July/August 1992): 4-7.

*American Forests Magazine*  
American Forests  
P.O. Box 2000  
Washington, DC 20013  
(202) 955-4500  
<http://www.amfor.org>  
[member@amfor.org](mailto:member@amfor.org)

National Urban & Community Forestry  
Advisory Council  
USDA Forest Service  
20628 Diane Drive  
Sonora, CA 95370  
(209) 536-9201  
<http://www.treelink.org/connect/orgs/nucfac/index.htm>  
[delvr@lodelink.com](mailto:delvr@lodelink.com)

Tree Link  
Urban & Community Forestry Resource  
<http://www.treelink.org>  
[info@treelink.org](mailto:info@treelink.org)

## Practice 6: Use Landscaping for Energy and Water Efficiency

### SOURCES

- Building Greener Neighborhoods. Trees as a Part of the Plan*. Washington, DC: American Forests and Home Builder Press of the National Association of Home Builders, 1995.
- Cooling Our Communities: A Guidebook on Tree Planting and Light-Colored Surfacing*. GPO Document 055-000-00371-8. Washington, DC: U.S. Environmental Protection Agency, January 1992.
- Georgia Water Wise Council. "Seven Principles of Xeriscape." *Southface Journal*, no. 1 (1994): 4-5.
- Landscaping for Energy Efficiency*. DOE/GO-10095-046, FS 220. Washington, DC: U.S. Department of Energy, Energy Efficiency and Renewable Energy Clearinghouse, April 1995.
- McPherson, Gregory, and James R. Simpson. "Shade Trees as a Demand-Side Resource." *Home Energy Magazine* 12, no. 2 (March/April 1995): 11-17.
- White, M. C., R. A. Etzel, W. D. Wilcox, and C. Loyd. "Exacerbations of Childhood Asthma and Ozone Pollution in Atlanta." *Environmental Research* 65 (1994): 56-68.
- Wilson, Alex. "Reconsidering the American Lawn." *Environmental Building News* 2, no. 4 (July/August 1993): 8-10.

### ADDITIONAL RESOURCES

- Marinelli, Janet, ed. *The Environmental Gardner*. New York: Brooklyn Botanic Garden, 1992.
- Moffat, Anne Simon, Marc Schiler, and the Staff of *Green Living. Energy-Efficient and Environmental Landscaping*. South Newfane, VT: Appropriate Solutions Press, 1995.

- Moll, Gary, and Sara Ebenreck, eds. *Shading Our Cities: A Resource Guide for Urban and Community Forests*. Washington, DC: Island Press, 1989.
- Wilson, Jim. *Landscaping with Wildflowers: An Environmental Approach to Gardening*. Boston: Houghton Mifflin Co., 1992.
- Xeriscape Landscaping: Preventing Pollution and Using Resources Efficiently*. EPA 840-B-93-001. U.S. Environmental Protection Agency, Office of Water, April 1993.

American Forests  
P.O. Box 2000  
Washington, DC 20013-2000  
(202) 9667-3300  
<http://www.amfor.org>

City of Austin Xeriscape Program  
Two Commodore Plaza  
206 E. 9th Street  
Austin, TX 78701  
(512) 499-3514  
<http://www.ci.austin.tx.us/watercon/xeriscape.htm>

Energy Efficiency and Renewable Energy  
Clearinghouse  
P.O. Box 3048  
Merrifield, VA 22116  
(800) 363-3732  
<http://www.eren.doe.gov>

Georgia Water Wise Council, Inc.  
1033 Franklin Road, Suite 9-187  
Marietta, GA 30067-8004  
<http://www.griffin.peachnet.edu/waterwise/wwc.htm>

Natural Resources Conservation Service  
Programs in Alabama  
<http://www.al.nrcs.usda.gov/programs.html>

Texas Agricultural Extension Service:  
Xeriscaping  
<http://www.pan-tex.net/usr/a/aggie/ag05054.htm>

## Practice 7: Manage Stormwater Naturally

### SOURCES

- Ferguson, Bruce K. *Introduction to Stormwater*. New York: John Wiley & Sons, 1998.
- The School of Environmental Design at the University of Georgia. *Land Development Provisions to Protect Georgia Water Quality*. Atlanta: Georgia Department of Natural Resources, Environmental Protection Division, October 1997.
- Wilson, Alex. "Stormwater Management: Environmentally Sound Approaches." *Environmental Building News* 3, no. 5 (September/October 1994): 1, 8–13.

## ADDITIONAL RESOURCES

- "Construction of Portland Cement Permeable Pavement." Florida Concrete and Products Association, 1998. (800) 324-0080.
- Nonpoint Pointers Factsheet Series. U.S. Environmental Protection Agency, Nonpoint Source Control Branch, March 1996. EPA-841-F-96-004. National Center for Environmental Publications and Information: (513) 489-8190.
- "Paving with Grass." *Environmental Building News* 3, no. 4 (July/August 1994): 6–7

Center for Watershed Protection  
8391 Main St.  
Ellicott City, MD 21043-4605  
(410) 461-8323  
<http://www.pipeline.com/~mrrunoff>

U.S. Environmental Protection Agency  
Region 4 Nonpoint Source Coordinator  
61 Forsyth Street SW  
Atlanta, GA 30303  
(404) 562-9900  
<http://www.epa.gov/OWOW/NPS/wpt/wpt02/index.html>

Grasspave2 Poured Pavement System  
Invisible Structures, Inc.  
20100 E. 35th Drive  
Aurora, CO 80011  
800-233-1510  
303-344-2233

## Practice 8: Reduce Irrigation Needs by Harvesting Water on Site

### SOURCES

- "Water Reuse Ponds Developed in Florida." *Watershed Protection Techniques* 1, no. 4 (Summer 1994).  
<http://www.epa.gov/OWOW/NPS/wpt/wpt02/wpt02-19.html>

## ADDITIONAL RESOURCES

- Graywater Guide: Using Graywater in Your Home Landscape*. Sacramento: California Department of Water Resources, 1994.
- Ludwig, Art. *Building Professional's Greywater Guide: The Guide to Professional Installation of Greywater Systems*. Santa Barbara, CA: Oasis Design, 1995.
- Ludwig, Art. *Create an Oasis with Greywater: Your Complete Guide to Managing Greywater in the Landscape*. Santa Barbara, CA: Oasis Design, 1994.
- Rainwater Collection Systems*. Morris Media Associates, 1995.
- Todd, Wendy Price, and Gail Vittori. *Texas Guide to Rainwater Harvesting*. Austin: Center for Maximum Potential Building Systems.

## Chapter 3: Sustainable Buildings: Floor Planning, Indoor Air Quality, Material Selection, and Waste Reduction

---

### Practice 1: Create Efficient Floor Plans

#### SOURCES

*Cascadia: An Energy Efficient, Affordable House Built with Stressed Skin Insulating Core Panels.* Eugene, OR: Energy Studies in Buildings Laboratory, University of Oregon, January 1997. (541) 346-5647.

National Association of Home Builders. *Cost-Effective Home Building: A Design and Construction Handbook.* Washington, DC: Home Builder Press, 1994.

Sullivan, Bruce. "Advanced Ways to Save Lumber, Energy, and Money." *Good Cents*, March/April 1995, 16–19.

Wilson, Alex. "Small Is Beautiful: House Size, Resource Use, and the Environment." *Environmental Building News* 8, no. 1 (January 1999): 1, 7–11.

#### ADDITIONAL RESOURCES

Dickinson, Duo. *Small Houses for the Next Century.* New York: McGraw-Hill, 1995.

Metz, Don, and Ben Watson, eds. *New Compact House Designs.* Pownal, VT: Storey Communications, 1991.

*Small Houses* (Fine Homebuilding). Newtown, CT: Taunton Press, 1995.

Tremblay, Kenneth R., and Lawrence Von Bamford, eds. *Small House Designs.* Pownal, VT: Storey Communications, 1997.

### Practice 2: Orient Buildings and Windows for Passive Solar Heating, Cooling, and Daylighting

#### SOURCES

Crosbie, Michael J., ed. *The Passive Solar Design and Construction Handbook.* New York: John Wiley & Sons, 1997.

Heede, Richard, et al. *Homemade Money: How to Save Energy and Dollars in Your Home.* Snowmass, CO: Rocky Mountain Institute, 1995.

Tiller, Jeffrey S., and Dennis B. Creech. "Passive Solar Homes—Designs for Today." In *Builder's Guide to Energy Efficient Homes in Georgia.* Atlanta: Georgia Environmental Facilities Authority, August 1996.

#### ADDITIONAL RESOURCES

Ander, Gregg D. *Daylighting Performance and Design.* New York: John Wiley & Sons, 1997.

Anderson, Bruce, and Malcolm Wells. *Passive Solar Energy: The Homeowner's Guide to Natural Heating and Cooling.* Amherst, NH: Brick House Publishing Company, 1994.

Kachadorian, Jim. *The Passive Solar House.* White River Junction, VT: Chelsea Green Publishing Co., 1997.

Wells, Karen Muller. *Building Solar.* New York: Van Nostrand Reinhold Company, 1984.

Florida Solar Energy Center  
1679 Clearlake Road  
Cocoa, FL 32922  
(407) 638-1000  
<http://www.fsec.ucf.edu>

International Solar Energy Society  
<http://www.ises.org>

Million Solar Roofs Initiative  
<http://www.eren.doe.gov/millionroofs>

Sustainable Building Industry Council (SBIC)  
1331 H Street NW, Suite 1000  
Washington, DC 20005  
(202) 628-7400  
<http://www.sbicouncil.org>  
[sbic@sbicouncil.org](mailto:sbic@sbicouncil.org)

Solar Energy Journal  
Elsevier Science  
P.O. Box 945  
New York, NY 10159-0945  
(888) 437-4636

*SOLAR TODAY Magazine*  
American Solar Energy Society  
2400 Central Avenue, G-1  
Boulder, CO 80301  
(303) 443-3130  
<http://www.csn.net/solar>  
[ases@ases.org](mailto:ases@ases.org)

### Practice 3: Specify Sustainable and Healthy Building Materials

#### SOURCES

*GREENSPEC: Specifications for Environmental Sustainability.* Newton Center, MA: Kalin Associates, 1996. (617) 964-5477

Malin, Nadav. "New Life for Old Carpets." *Environmental Building News* 6, no. 6 (June 1997): 1, 8–13.

#### ADDITIONAL RESOURCES

Chappell, Steve, ed. *The Alternative Building Sourcebook.* Brownfield, ME: Fox Maple Press, 1998.

*Cost-Effective Homebuilding: A Design and Construction Handbook.* Upper Marlboro, MD: National Association of Homebuilders Research Center, 1994.



*Environmental Building News Product Catalog*. E Build, Inc., and What's Working, 1998. (802) 257-7300.

Lstiburek, Joseph. *Builder's Guide: Mixed Climates*. Westford, MA: Building Science Corporation, 1997.

Meadows, Dru, and Charles Bell. *The Green Home Product Guide*. Tulsa, OK: The Green Team, 1998. (918) 742-7593.

Sullivan, Bruce, and Beth Magee, eds. *REDI: Resources for Environmental Design Index*. Eugene, OR: Iris Communications, 1998. (541) 484-9353.

Building Science Corporation  
70 Main Street  
Westford, MA 01886  
(508) 589-5100  
<http://www.buildingscience.com>

Center of Excellence for Sustainable Development  
Green Buildings: Articles and Publications  
<http://www.sustainable.doe.gov/articles/houseart.htm>

*Energy Design Update*  
Newsletter on Energy-Efficient Housing  
Cutter Information Corp.  
37 Broadway, Suite 1  
Arlington, MA 02474-5552  
(800) 964-5118  
<http://www.cutter.com/energy>

*Journal of Light Construction*  
Builderburg Group, Inc.  
932 West Main Street  
Richmond, VT 05477  
(800) 375-5981

Oikos: Green Building Source  
Sustainable Design and Construction Information  
<http://oikos.com>

SpecNet  
<http://www.spec-net.com>

## Practice 4: Design Interiors That Ensure Healthy Indoor Air Quality (IAQ)

### SOURCES

Tiller, Jeffrey S., and Dennis B. Creech. *Builder's Guide to Energy Efficient Homes in Georgia*. Atlanta: Georgia Environmental Facilities Authority, August 1996.

### ADDITIONAL RESOURCES

*ASHRAE Standard 62-1989: Ventilation for Acceptable Indoor Air Quality*. Atlanta: ASHRAE, 1989. (404) 636-8400.

Bower, John. *Understanding Ventilation*. Bloomington, IN: Healthy House Institute, 1995.

DuPont, Peter, and John Morrill. *Residential Indoor Air Quality and Energy Efficiency*. Washington, DC: American Council for an Energy Efficient Economy, 1989.

Hays, Steve, Ronald Gobbell, and Nicholas Ganick. *Indoor Air Quality: Solutions and Strategies*. New York: McGraw-Hill, 1995.

*Indoor Environmental Quality (IEQ) Strategies Materials Specifications Guide*. Arlington, MA: Cutter Information Corp., 1991.

## Practice 5: Prevent Moisture, Radon, and Soil Gases from Entering Homes

### SOURCES

Tiller, Jeffrey S., and Dennis B. Creech. *Builder's Guide to Energy Efficient Homes in Georgia*. Atlanta: Georgia Environmental Facilities Authority, August 1996.

### ADDITIONAL RESOURCES

*Citizen's Guide to Radon: The Guide to Protecting Yourself and Your Family from Radon*. 2nd edition. EPA 402-K92-001. Washington, DC: U.S. Environmental Protection Agency, September 1994.

Coffel, Steve, and Karyn Feiden. *Indoor Pollution*. New York: Fawcett Columbine, 1990.

*Consumer's Guide to Radon Reduction: How to Reduce Radon Levels in Your Home*. EPA 402-K2-003. Washington, DC: U.S. Environmental Protection Agency, August 1992.

*Introduction to Indoor Air Quality: A Reference Manual*. Washington, DC: U.S. Environmental Protection Agency, Office of Air and Radiation, July 1991.

Lstiburek, Joseph, and John Carmody. *Moisture Control Handbook: Principles and Practices for Residential and Small Commercial Buildings*. New York: Van Nostrand Reinhold, 1994.

*Model Standards and Techniques for Control of Radon in New Residential Buildings*. Washington, DC: U.S. Environmental Protection Agency. For a free copy call (800) 55RADON.

*Radon Reduction Techniques for Detached Houses*. EPA/625/5-87/019. Washington, DC: U.S. Environmental Protection Agency, Air and Energy Engineering Research Laboratory, 1988.

National Association of Home Builders  
Energy and Home Environment Department  
(800) 368-5242, ext. 244

State Radon Contacts  
Alabama (800) 862-1866  
Florida (800) 543-8279  
Georgia (800) 745-0037  
North Carolina (919) 733-3410  
South Carolina (800) 768-0362

## Practice 6: Reduce Job Site Waste and Use Building Materials Efficiently

### SOURCES

Thaut, Philip. "The Six Big Profit Killers." *Journal of Light Construction* 15, no. 3 (December 1996).

Yost, Peter, and Eric Lund. *Residential Construction Waste Management: A Builder's Field Guide—How to Save Money and Landfill Space*. Upper Marlboro, MD: National Association of Home Builders Research Center, 1997.

#### ADDITIONAL RESOURCES

Edminster, Ann, and Sami Yassa. *Efficient Wood Use in Residential Construction*. New York: Natural Resources Defense Council, 1998.

Mumma, Tracy. *Guide to Resource-Efficient Building Elements*. 6th edition. Missoula, MT: Center for Resourceful Building Technology, 1997.

*Resource-Efficient Building: Reducing Material Use, Toxicity and Waste in Design and Construction*. Minneapolis: Waste Reduction Institute for Training & Applications Research (WRITAR), March 1995.

The Center for Resourceful Building Technology  
P.O. Box 100  
Missoula, MT 59806  
(406) 549-7678

Environmental Building News  
Newsletter on Environmentally Responsible  
Design and Construction  
28 Birge Street  
Brattleboro, VT 05301  
(802) 257-7300  
<http://www.ebuild.com>  
[ebn@ebuild.com](mailto:ebn@ebuild.com)

*Journal of Light Construction*  
Builderburg Group, Inc.  
932 West Main Street  
Richmond, VT 05477  
(800) 375-5981

National Association of Home Builders Research  
Center  
400 Prince George's Boulevard  
Upper Marlboro, MD 20774  
(301) 249-4000  
<http://www.nahbrc.com>

Waste Reduction Institute for Training and  
Applications Research  
1313 5th Street SE  
Minneapolis, MN 55414-4502  
(612) 379-5995

## Chapter 4: Sustainable Buildings: Energy-Efficient Design and Construction

---

### Practices 1 & 2: Create Continuous Air Barrier & Create Continuous Insulation Barrier

#### SOURCES

Tiller, Jeffrey S., and Dennis B. Creech. *Builder's Guide to Energy Efficient Homes in Georgia*. Atlanta: Georgia Environmental Facilities Authority, August 1996.

#### ADDITIONAL RESOURCES

Andrews, Steve. *Foam-Core Panels & Building Systems: Principles, Practice, and Product Directory*. Arlington, MA: Cutter Information Corp., 1992.

*Energy Efficient Framing Fact Sheet*. Upper Marlboro, MD: National Association of Home Builders Research Center, October 1997.

*Insulation Fact Sheet*. DOE/CE-0180. Washington, DC: U.S. Department of Energy, Energy Efficiency and Renewable Energy, 1997. Also available at <http://www.ornl.gov/roofs+walls/insulation/index.html>

Maloney, Jim. *Advanced Air Sealing — Simple Techniques for Air Leakage Control in Residential Buildings*. New York: Iris Communications, 1993.

Myhrman, Matt, and Steve MacDonald. *Build It with Bales*. 2nd edition. White River Junction, VT: Chelsea Green Publishing Co., 1997.

*Home Energy*  
Magazine of residential energy conservation  
2124 Kittredge St., No. 95  
Berkeley, CA 94704  
(510) 524-5405  
<http://www.homeenergy.org>  
[homeenergy@anl.gov](mailto:homeenergy@anl.gov)

National Association of Home Builders Research  
Center  
400 Prince George's Boulevard  
Upper Marlboro, MD 20774  
(301) 249-4000  
<http://www.nahbrc.com>

Oak Ridge National Laboratory  
Buildings Technology Center, Building Envelope  
Research  
P. O. Box 2008, MS 6070  
Oak Ridge, TN 37831-6070  
(865) 574-0022  
<http://www.ornl.gov/roofs+walls/desjarlaises@ornl.gov>

*Solplan Review*  
Journal of energy conservation, building science,  
and construction practice  
The Drawing-Room Graphic Services Ltd.  
Box 86627  
North Vancouver, BC V7L 4L2  
(604) 689-1841  
solplan@direct.ca

### Practice 3: Specify Properly Sized, High-Efficiency HVAC Equipment

#### SOURCES

Tiller, Jeffrey S., and Dennis B. Creech. *Builder's Guide to Energy Efficient Homes in Georgia*. Atlanta: Georgia Environmental Facilities Authority, August 1996.

#### ADDITIONAL RESOURCES

*Bigger Is Not Better — When it Comes to Air-Conditioned Comfort*. U.S. Environmental Protection Agency and U.S. Department of Energy, Energy Star Program.

Bower, John. *Understanding Ventilation*. Bloomington, IN: The Healthy House Institute, 1995.

Habitat for Humanity International et al. *Instructions for Heating, Ventilating & Air Conditioning Contractors*.

Hayden, A.C.S. "Choosing a Heating System That Saves Energy." *Home Energy Magazine* 13, no. 5 (March/April 1996): 27–29.

Proctor, John, Zinovy Katnelson, and Brad Wilson. "Sizing Air Conditioners." *Journal of Light Construction* 14, no. 11 (August 1996): 29–32.

Air Conditioning Contractors of America (ACCA)  
1712 New Hampshire Ave. NW  
Washington, DC 20009  
(202) 483-9370  
<http://www.acca.org>  
[info@acca.org](mailto:info@acca.org)

The American Society of Heating, Refrigerating and Air-Conditioning Engineers (ASHRAE)  
1791 Tullie Circle NE  
Atlanta, GA 30329  
(404) 636-8400  
<http://www.ashrae.org>  
[ASHRAE@ASHRAE.org](mailto:ASHRAE@ASHRAE.org)

California Energy Commission Appliance Efficiency Database  
<http://www.energy.ca.gov/efficiency/appliances/>

Geothermal Heat Pump Consortium, Inc.  
701 Pennsylvania Ave. NW  
Washington, DC 20004-2696  
(888) ALL-4-GEO  
<http://www.ghpc.org>  
[info@ghpc.org](mailto:info@ghpc.org)

Oak Ridge National Laboratory  
Buildings Technology Center, Heating and Cooling  
Equipment Research  
P.O. Box 2008, MS 6070  
Oak Ridge, TN 37831-6070  
(865) 574-2020  
[http://www.ornl.gov/ORNL/BTC/h\\_and\\_c.htm](http://www.ornl.gov/ORNL/BTC/h_and_c.htm)

U.S. Department of Energy Office of Codes and Standards  
[http://www.eren.doe.gov/buildings/consumer\\_information/index.html](http://www.eren.doe.gov/buildings/consumer_information/index.html)

### Practice 4: Design and Install Ductwork and Filters Properly

#### SOURCES

Tiller, Jeffrey S., and Dennis B. Creech. *Builder's Guide to Energy Efficient Homes in Georgia*. Atlanta: Georgia Environmental Facilities Authority, August 1996.

#### ADDITIONAL RESOURCES

Barcik, Mike. "Breathing Easy . . . Thanks to Duct and Air Sealing." *Southface Journal*, no. 2 (1998): 15–17.

Cummings, James B., John J. Tooley, and Neil Moyer. *Duct Doctoring*. Cocoa, FL: Florida Solar Energy Center, 1992.

Maloney, Jim. *Advanced Air Sealing—Simple Techniques for Air Leakage Control in Residential Buildings*. New York: Iris Communications, 1993. Pp. 25–26.

Stum, Karl. "Guidelines for Designing and Installing Tight Duct Systems." *Home Energy Magazine* 10, no. 5 (September/October 1993): 24–29.

Tiller, Jeff, and Dennis Creech. *Sealing Your Home's Ductwork*. Atlanta: Georgia Governor's Office of Energy Resources.

### Practice 5: Prevent Interior Moisture Buildup with Controlled Ventilation

#### SOURCES

Tiller, Jeffrey S., and Dennis B. Creech. *Builder's Guide to Energy Efficient Homes in Georgia*. Atlanta: Georgia Environmental Facilities Authority, August 1996.

#### ADDITIONAL RESOURCES

Bower, John. *Understanding Ventilation*. Bloomington, IN: The Healthy House Institute, 1995.

Lstiburek, Joseph. "How to Control Moisture in Houses." *Custom Builder*. December 1997: 9–10.

Lstiburek, Joseph, and John Carmody. *Moisture Control Handbook: Principles and Practices for Residential and Small Commercial Buildings*. New York: Van Nostrand Reinhold, 1994.

Luepke, Gary. "Practice the Basics of Microbial Growth Control." *Contracting Business*, July 1997, 12–15.

## Practice 6: Specify Energy-Efficient Windows and Doors

### SOURCES

Tiller, Jeffrey S., and Dennis B. Creech. *Builder's Guide to Energy Efficient Homes in Georgia*. Atlanta: Georgia Environmental Facilities Authority, August 1996.

### ADDITIONAL RESOURCES

Carmody, John, Stephen Selkowitz, and Lisa Heshcong. *Residential Windows: A Guide to New Technologies and Energy Performance*. New York: W.W. Norton, 1996.

"Composite Window Offers Superior Thermal Performance, Strength." *Energy Design Update* 18, no. 3 (March 1998): 14.

Warner, Jeffrey L. "Consumer Guide to Energy-Saving Windows." *Home Energy Magazine* 7, no. 4 (July/August 1990): 17–22.

Wilson, Alex. "Windows: Looking through the Options." *Environmental Building News*, March 1998.

"Window Technology Upgrades." *SOLPLAN Review*, no. 78 (January 1998): 5–6.

Efficient Windows Collaborative  
Alliance to Save Energy  
1200 18th Street NW, Suite 900  
Washington, DC 20036  
(202) 857-0666  
<http://www.efficientwindows.org/award@ase.org>

Fine Homebuilding  
(800) 283-7252 (magazine information)  
(800) 888-8286 (subscriptions)  
<http://www.finehomebuilding.com>

National Fenestration Rating Council  
1300 Spring Street, Suite 500  
Silver Spring, MD 20910  
(301) 589-6372  
<http://www.nfrc.org/index.htm>

## Practice 7: Install Energy-Efficient Water Heating

### SOURCES

Tiller, Jeffrey S., and Dennis B. Creech. *Builder's Guide to Energy Efficient Homes in Georgia*. Atlanta: Georgia Environmental Facilities Authority, August 1996.

## Practice 8: Design Energy-Efficient Lighting

### SOURCES

Tiller, Jeffrey S., and Dennis B. Creech. *Builder's Guide to Energy Efficient Homes in Georgia*. Atlanta: Georgia Environmental Facilities Authority, August 1996.

### ADDITIONAL RESOURCES

Leslie, Russell P., and Kathryn M. Conway. *The Lighting Pattern Book for Homes*. New York: McGraw-Hill, 1996.

Rembert, Tracey. "The Eternal Flame: Compact Fluorescents Are Cheap, Earth-Friendly and May Last Forever." *E Magazine* 7, no. 4 (July/August 1996): 44–45.

Rorer, Paul. "Lighting Advances Create More Choices for End Users." *Energy User News* 22, no. 9 (September 1997): 18–20.

Energy Efficient Lighting Association  
P.O. Box 727  
Princeton Junction, NJ 08550  
(609) 799-4900  
<http://www.eela.com>  
[eela@eela.com](mailto:eela@eela.com)

Lighting Research Center  
Rensselaer Polytechnic Institute  
110 8th Street  
Watervliet Facility  
Troy, NY 12180  
(518) 276-8716  
<http://www.lrc.rpi.edu/>  
[lrc@rpi.edu](mailto:lrc@rpi.edu)

## Practice 9: Specify High-Quality, Water-Saving Faucets and Fixtures

### SOURCES

Small Homes Council—Building Research Council, *Building Council Notes—Water Conservation*. C1.6, vol. 2, no. 3.

Liebold, Warren. "The Toilet Conservationists Like Best." *Home Energy Magazine* 14, no. 2 (March/April 1997): 9–10.

Jade Mountain Inc.  
P.O. Box 4616  
Boulder, CO 80306  
(800) 442-1972  
<http://www.jademountain.com>

PlumbingMart.com  
<http://www.plumbingmart.com/welcome.html>

## Practice 10: Specify Energy-Efficient Refrigerators and Appliances

### SOURCES

Heed, Richard, et al. *Homemade Money: How to Save Energy and Dollars in Your Home*. Snowmass, CO: Rocky Mountain Institute, 1995.

Tiller, Jeffrey S., and Dennis B. Creech. *Builder's Guide to Energy Efficient Homes in Georgia*. Atlanta: Georgia Environmental Facilities Authority, August 1996.

**ADDITIONAL RESOURCES**

- Betts, Kellyn S. "The Coming Green Computers." *E Magazine* 5, no. 2 (April 1994): 28–35.
- Kelley, Julia. "Town Awash in H-Axis Machines." *Home Energy Magazine* 15, no. 3 (May/June 1998): 11–12.
- Meier, Alan. "First Patch on Leaky Electricity." *Home Energy Magazine* 15, no. 3 (May/June 1998): 7.
- U. S. Federal Trade Commission. *Facts for Consumers: Energy Guide to Major Home Appliances*. Washington, DC: Government Printing Office, 1996.
- Wilson, Alex, and John Morrill. *Consumer Guide to Home Energy Savings*. 6th edition. Washington, DC: American Council for an Energy Efficient Economy, 1998.
- American Council for an Energy Efficient Economy (ACE<sup>3</sup>)  
1001 Connecticut Ave. NW, Suite 801  
Washington, DC 20036  
Research and Conferences: (202) 429-8873  
Publications: (202) 429-0063  
<http://www.aceee.org>
- Appliance Magazine Online  
[appliance.com](http://www.appliance.com)  
<http://www.appliance.com>
- California Energy Commission Appliance Efficiency Database  
<http://www.energy.ca.gov/efficiency/appliances/>

ENERGY STAR® Appliances  
(888) STAR-YES  
<http://www.energystar.gov/products/appliances.html>  
[info@energystar.gov](mailto:info@energystar.gov)

U.S. Department of Energy Office of Codes and Standards  
[http://www.eren.doe.gov/buildings/consumer\\_information/index.html](http://www.eren.doe.gov/buildings/consumer_information/index.html)

*The following resources pertain to several of the practices discussed in Chapter 4.*

**ADDITIONAL RESOURCES**

Center for Maximum Potential Building Systems  
8604 F.M. 969  
Austin, Texas 78724  
(512) 928-4786  
<http://www2.cmpbs.org/cmpbs/cmpbs@greenbuilder.com>

Energy Efficient Building Association (EEBA)  
1300 Spring Street, Suite 500  
Silver Springs, MD 20910  
301-589-2500  
<http://www.eeba.org>  
[info@eeba.org](mailto:info@eeba.org)



## Green Builder Programs, Energy-Efficient Mortgages, and Third Party-Certification

### Introduction

Sustainable building practices produce highly desirable and marketable homes. Energy-efficient homes are healthy, comfortable, and durable, with reduced utility and maintenance costs. These features will distinguish your homes from others and can make homebuyers eligible for preferred mortgage financing.

While green features may cost more initially, they can help homes sell more easily and at a higher profit. In fact, 53% of homebuyers were willing to pay an extra \$1,000 to \$5,000 for healthy house features, according to the 1993 Professional Building Consumer Survey on housing. A 1998 study found that a home's value increases by \$20 for each \$1 saved in average annual utility costs.

Wide marketing of green home features—to homebuyers, real estate agents, and lenders—is key to easier home sales. That's where participating in a green building program can help. Across the country, these programs are helping builders market their green practices.

Energy-efficient mortgages and independent certification also help market green built homes. Because monthly utility costs are lower, lenders can put together an energy-efficient mortgage, qualify more homebuyers, and increase profits. Independent certification ensures that buyers get the quality product promised and is often required by green builder programs.

### Green Building Programs

Green building programs offer builders an opportunity to market the sustainable features of their homes and provide buyers with a yardstick to compare green buildings. Benefits for the green builder include

- **More profit per home.** With an energy-efficient home, buyers can afford more home or more upscale options for the same cost as a standard home.
- **Greater sales.** Participation in a green building program can enhance the recognition and reputation of your homes through joint marketing programs and interested local media.
- **Fewer callbacks.** Green building practices emphasize homeowner comfort, health, and a more durable product.

The program known as *EarthCraft House*<sup>SM</sup>—*Sensibly Built for the Environment* awards points for green practices in site development, design, construction, consumer education, and marketing (see Appendix C). Builders must score a designated minimum number of points to certify a home under the program. EarthCraft House was created by the Greater Atlanta Home Builders Association in conjunction with the National Association of Home Builders Research Center and Southface Energy Institute. The Atlanta market was chosen as the pilot city for the program, with the goal of making EarthCraft House available to all home builder associations across the country.

The U.S. Environmental Protection Agency and Department of Energy's *ENERGY STAR Homes Program* assists builders in creating homes with improved energy efficiency. ENERGY STAR Homes are at least 30% more energy-efficient than is called for by the current national 1992 Model Energy Code.

The city of Austin's residential *Green Building Program* uses a five-star rating system with a menu of options for builders. The program covers five areas: energy efficiency, water efficiency, materials efficiency, health and safety, and community. The city developed the free program, which includes home ratings, marketing support for members, technical seminars, and consultation services. Currently, the program is a service of the city's municipal utility.

The *Green Builder Program of Colorado* (GBPC) expanded from the Denver green builder program. Currently, builders and remodelers join the program on an annual basis and register individual homes to receive the BUILT GREEN label. Homes must meet criteria focused on increasing energy efficiency while also addressing improved land use, waste management, materials use, indoor air quality, and water efficiency. The program includes an extensive marketing and education partnership with state government, utilities, and other sponsors.

The Home Builders Association of Central New Mexico's *Green Builder* program recognizes sustainably built homes with a four-star rating system. The program encourages actions in four categories: energy conservation, materials conservation, waste reduction, and water conservation. The program includes builder flexibility and spot checking for compliance and is open to association members and nonmembers.

The *Building Green* program of the Suburban Maryland Building Industry Association (SMBIA) targets both builders and developers. Key areas for improvement for builders are water savings, on-lot water runoff control, building materials, and energy efficiency. For developers, key elements include land-planning strategies, environmental protection and enhancement, road design, landscaping, septic systems, storm water management, amenities, and special projects. The program was developed by and for members of SMBIA.

The Home Builders Association of Kitsap County, Washington, uses *Build a Better Kitsap* to promote sustainable building. With a three-level rating system, builders can receive points for more than 80 different actions in eight major categories: codes and regulation, proper site treatment, reduce/reuse/recycle, resource-efficient products, energy efficiency, good air quality and health, proper hazardous waste management, and environmentally responsible home ownership. The program uses a handbook that links actions with local resources and includes a significant homeowner education component. The program will include a focus on remodeling in the future.

The *Scottsdale Green Building* program in Arizona uses a point system to encourage sustainable and healthy building practices in new homes. The voluntary program focuses on five impact areas—energy, building materials, water, solid waste, and indoor air quality—and is open to all builders in the city of Scottsdale. Currently, an independent inspection is not required to obtain certification although the city does perform random



inspections during critical phases of construction and a final inspection.

The *Green Points* program in Boulder, Colorado, enables builders to earn points for energy and resource-efficient features that fall under land use, framing, plumbing, electrical, insulation, HVAC, solar, and indoor air quality categories. This program is unique among those across the country because participation is required to obtain a building permit.

The Clark County Home Builder Association in Vancouver, Washington, is developing a Green Building program closely modeled after the one in Kitsap County. The National Association of Home Builders Research Center has created a guide for associations to use in creating their own green builder programs.

Another approach is that of the University of Florida's *Build Green and Profit*, a 14-credit-hour continuing education program that reviews green building practices and provides techniques for marketing these practices.

For commercial buildings, the U.S. Green Builder Council is developing the Leadership in Energy and Environmental Design (LEED<sup>™</sup>) Green Building Rating System. LEED is a voluntary rating system for commercial buildings currently being developed to provide a national consensus and market incentives for green building. A residential version of LEED will follow implementation of the commercial version.

### Energy-Efficient Mortgages

Energy-efficient mortgages (EEMs) are useful tools to help sell green-built homes. With energy-efficient mortgages, different finance options are available depending on the lender or the type of green building program. These mortgages help make it easier for homebuyers to qualify for energy-efficient homes or to afford a more costly home at a given income. For example, preferred

terms for homebuyers purchasing ENERGY STAR Homes through an ENERGY STAR Mortgage can include

- Cash back at closing
- Increased debt-to-income ratio
- Assured appraisal values
- Free interest lock
- Reduced loan origination fees
- Discounted interest rates

To find out if EEMs are available in your area, contact the Residential Energy Services Network (RESNET) at [www.natresnet.org/dir/lenders/](http://www.natresnet.org/dir/lenders/).

### Independent Home Energy Rating

Another key to marketing a green home, often used in conjunction with a green building program and usually required with energy-efficient mortgages, is an independent home energy rating. Sometimes builders make claims about the energy efficiency of their homes that are not substantiated by actual homeowner experience. So even if a home is designed and built to high energy-efficiency standards, independent testing of homes to verify performance provides third-party confirmation of quality and savings. Especially if you are not part of a green building program but are building energy-efficient homes, getting your homes certified by an outside party can provide marketing advantages.

The states that currently have RESNET-accredited home energy rating systems (HERS) operating in them are the following: Alabama, Alaska, Arkansas, Colorado, Florida, Georgia, Indiana, Iowa, Kansas, Louisiana, Massachusetts, Michigan, Mississippi, Nevada, North Carolina, Ohio, Oregon, Rhode Island, South Carolina, Utah, Vermont, West Virginia, and Wisconsin. For the latest information on HERS providers, check [www.natresnet.org/dir/HERSsys.htm](http://www.natresnet.org/dir/HERSsys.htm).

## Contacts and Resources

Following is contact information for the organizations and programs mentioned above.

**EPA ENERGY STAR Homes Program and ENERGY STAR Mortgages**  
888-STAR-YES  
<http://www.energystar.gov>  
[info@energystar.gov](mailto:info@energystar.gov)

Marc Richmond-Powers, *Director*  
**City of Austin**  
**Green Building Program**  
206 E. 9th St., Suite 17102  
Austin, TX 78701  
512-499-3029  
<http://www.ci.austin.tx.us/greenbuilder/>  
[marc.richmond@ci.austin.tx.us](mailto:marc.richmond@ci.austin.tx.us)

Kim Calomino, *Program Administrator*  
**BUILT GREEN**  
**Green Builder Program of Colorado**  
HBA of Metropolitan Denver  
1400 S. Emerson  
Denver, CO 80210  
303-778-1400  
<http://www.hbadenver.com/green/>

Anna Mayberry, *Program Coordinator*  
**HBA of Central New Mexico**  
5931 Office Blvd. NE  
Albuquerque, NM 87109  
505-344-3294

Suzanne Charleston, *Program Coordinator*  
**Building Green Program**  
**Suburban Maryland Building Industry Association**  
1738 Elton Road, Suite 200  
Silver Spring, MD 20903  
301-445-5400  
<http://www.smbia.org/page25.html>  
[building@smbia.org](mailto:building@smbia.org)

Art Castle, *Executive Director*  
**HBA of Kitsap County**  
5251 Auto Center Way  
Bremerton, WA 98312-3319  
360-479-5778  
<http://www.kitsaphba.com>

**City of Scottsdale**  
**Environmental Management Office**  
7447 E. Indian School Road, Suite 200  
Scottsdale, AZ 85251  
602-944-7990  
<http://www.ci.scottsdale.az.us/environmental/greenbuilding/>

**City of Boulder**  
**Green Points Building Program**  
PO Box 791  
Boulder, CO 80306-0791  
303-441-3090  
[http://environmentalaffairs.ci.boulder.co.us/residential/gp\\_overview.html](http://environmentalaffairs.ci.boulder.co.us/residential/gp_overview.html)

Philip Ford, *Director, Governmental Affairs*  
**Earth Craft House<sup>SM</sup>**  
**Greater Atlanta Home Builders Association**  
PO Box 450749  
Atlanta, GA 31145  
770-938-9900 x 20  
[ecraft@vivid.net](mailto:ecraft@vivid.net)

Karen Snekvik, *Executive Director*  
**Clark County HBA**  
5007 NE St. John's Rd  
Vancouver, WA 98661  
360-694-0933

**National Association of Home Builders**  
**Research Center**  
Green Building Activities  
Prince Georges Blvd.  
Upper Marlboro, MD 20774-8731  
301-249-4400 ext. 542  
<http://www.nahbrc.org/xbuilder.htm>  
Craig Miller

**Build Green and Profit**  
**Florida Energy Extension Service**  
University of Florida  
PO Box 110940  
Gainesville, FL 32611-0940  
352-392-5684  
Fax: 352-392-9033  
<http://hammock.ifas.ufl.edu/sustain/buildgreen/buildgreen.html>

**US Green Building Council**  
110 Sutter Street, Suite 906  
San Francisco, CA 94101  
415-445-9500  
<http://www.usgbc.org>  
[info@usgbc.org](mailto:info@usgbc.org)

**Residential Energy Services Network (RESNET)**  
PO Box 4561  
Oceanside, CA 92052-4561  
[resnet@earthlink.net](mailto:resnet@earthlink.net)  
<http://www.natresnet.org/herseems/default.htm>  
(link to HERS and EEMs)

**Energy Rated Homes of America**  
PO Box 4561  
Oceanside, CA 92052-4561  
760-806-3448  
[info@erha.com](mailto:info@erha.com)  
<http://www.erha.com/about.htm>

# EarthCraft House<sup>SM</sup>—Worksheet



Builders must submit a Final Worksheet for each EarthCraft House<sup>SM</sup>. The Workspace column provides a tracking area for targeting the points you want to score. The Final column represents the specific measures you pledge to include for this house. An EarthCraft House<sup>SM</sup> certification requires **150 points**.

The EarthCraft House<sup>SM</sup> program is sponsored by the Greater Atlanta Home Builder’s Association in cooperation with private industry and government. Submit this form to: **Jim Hackler, Project Director, 241 Pine St., Atlanta, GA 30308**, by fax: **404/872-5009**. For information, contact EarthCraft House<sup>SM</sup> at **404/872-3549** ext. 118, or by email: **earthcraft@earthcrafthouse.com**.

Builder: \_\_\_\_\_

Contact: \_\_\_\_\_

Telephone: \_\_\_\_\_ Fax: \_\_\_\_\_ E-mail: \_\_\_\_\_

EarthCraft House<sup>SM</sup> address or lot number: \_\_\_\_\_

**Builder**—By accepting the EarthCraft House<sup>SM</sup> certification, I pledge that this house has been constructed to the standards listed on the Final Worksheet.

**Home Buyer**—I have reviewed the EarthCraft House<sup>SM</sup> measures with the homebuilder or sales agent

\_\_\_\_\_  
Builder Signature date

\_\_\_\_\_  
Home Buyer Signature (required only for pre-sales) date

**EarthCraft Home Inspection**

\_\_\_\_\_  
Address

\_\_\_\_\_  
Inspector Signature date

	POINTS	WORKSPACE	FINAL
<b>SITE PLANNING</b>			
erosion control site plan	8		
workshop on erosion and sediment control	2		
topsoil preservation	5		
grind stumps and limbs for mulch	3		
mill cleared logs	2		
<b>Building With Trees (NAHB program)</b>	<b>25</b>		
<b>OR</b> builder may choose to certify house meets Building With Trees program <i>OR</i> earn points from individual tree protection and planting measures			
<b>Tree Protection and Planting Measures</b>			
tree preservation plan	5		
no trenching through tree root zone (per tree)	1		
no soil compaction of tree root zone	2		
undisturbed areas	1		
tree planting	4		
wildlife habitat	2		

<b>ENERGY EFFICIENT BUILDING ENVELOPE AND SYSTEMS</b>	
<b>ENERGY STAR</b>	90
<b>OR</b> builder may choose to certify house meets <i>ENERGY STAR</i> <i>OR</i> earn a minimum of 75 points from <i>Energy Measures</i>	
<b>Energy Measures</b> (must earn a minimum of 75 points, Energy Measure points cannot exceed 85 points) <i>Houses must meet or exceed the Georgia Energy Code</i>	
<b>AIR LEAKAGE TEST</b> <i>Builder must provide documented proof of certified test to homeowner</i>	
Certify maximum 0.35 air changes per hour <i>OR</i> earn points for individual <i>air sealing measures</i>	35
<b>AIR SEALING MEASURES</b> <i>maximum 30</i>	
bottom plate of exterior walls	2
floor penetrations between unconditioned and conditioned space	2
bath tub and shower drain	2
cantilevered floors sealed above supporting wall	2
drywall sealed to bottom plate of exterior walls	2
fireplace air sealing package (all units)	2
drywall penetrations in exterior walls	2
exterior wall sheathing sealed at plates, seams, and openings	5
housewrap (unsealed at seams and openings)	2
housewrap (sealed at plates, seams, and openings)	8
window rough openings	2
door rough openings	1
airtight IC recessed lights or no recessed lights in insulated ceilings	4
attic access opening (pulldown stairs/ scuttle hole)	2
attic kneewall doors (weatherstripped with latch)	2
attic kneewall has sealed exterior sheathing	5
chases sealed and insulated	5
ceiling penetrations sealed between unconditioned and conditioned space	2
ceiling drywall sealed to top plate	2
band joist between conditioned floors sealed	3
<b>AIR SEALING MEASURES SUB TOTAL</b>	
<b>INSULATION</b> <i>*Homes with multiple foundation types must use foundation type of greatest area for points</i>	
*slab insulation	2
*basement walls (continuous floor to ceiling R10)	3
*framed floor over unconditioned space (R19)	1
*sealed, insulated crawl space walls (R10)	1
*cantilevered floor (R30)	2
insulate fireplace chase	1
spray applied wall insulation	4
exterior wall stud cavities (R15)	1
insulated headers	2
insulated corners	2
insulated T-walls (exterior/ interior wall intersection)	2

	POINTS	WORKSPACE	FINAL
insulated wall sheathing (R 2.5 or greater)	2		
insulated wall sheathing (R 5 or greater)	3		
band joist insulated (R19)	2		
loose-fill attic insulation card and rulers	1		
energy heel trusses or raised top plate	2		
flat ceilings (R30)	1		
flat ceilings (R38)	2		
vaulted and tray ceilings (R25)	1		
vaulted and tray ceilings (R30)	2		
ceiling radiant heat barrier	1		
attic kneewall stud cavities (min R19)	3		
attic kneewall with insulated sheathing (R5)	5		
attic kneewall doors (R19)	2		
attic access doors (R19)	2		
<b>INSULATION SUBTOTAL</b>			
<b>WINDOWS</b>			
NFRC rated windows (max U.56)	3		
low emissivity glazing	5		
gas-filled double glazed units	3		
solar heat gain coefficient (max 0.4)	3		
1.5-foot overhangs on all sides	1		
solar shade screens	3		
west facing glazing less than 2% of floor area	2		
east facing glazing less than 3% of floor area	2		
certified passive solar design (25% load reduction)	10		
<b>WINDOWS SUBTOTAL</b>			
<b>HEATING AND COOLING EQUIPMENT</b> <i>*Builder must provide documented proof</i>			
*cooling equipment sized within 10% of Manual J (all units)	5		
*heating equipment sized within 10% of Manual J (all units)	5		
*measured airflow within 10% of manufacturer's specifications	3		
90% AFUE furnace (per unit)	3		
SEER 12 cooling equipment (per unit)	2		
SEER 14 cooling equipment (per unit)	3		
HSPF 7.8 heat pump	2		
HSPF 8.0 heat pump	3		
geothermal heat pump	4		
*sensible heat fraction (max 0.7, all units)	2		
programmable thermostat	1		
outdoor thermostat for heat pump	1		
*cooling equipment has non CFC or HCFC refrigerant	3		
zone control—one system services multiple zones	5		
<b>HEATING AND COOLING SUBTOTAL</b>			

	POINTS	WORKSPACE	FINAL
<b>DUCTWORK/ AIR HANDLER</b> <i>*Builder must provide documented proof of certification to homeowner</i>			
*certify duct leakage less than 5%	20		
air handler located within conditioned space (all units)	5		
ducts located within conditioned space (min 90%)	5		
duct seams and air handler sealed with mastic	10		
*duct design complies with Manual D	5		
*airflow for each duct run measured and balanced	3		
no ducts in exterior walls	3		
longitudinal supply trunk	1		
multiple return ducts	2		
interior doors with 1-inch clearance to finish floor	2		
duct trunk lines outside conditioned space insulated to R8	2		
<i>DUCTWORK/ AIR HANDLER SUBTOTAL</i>			
<i>ENERGY EFFICIENT BUILDING ENVELOPE SUBTOTAL—minimum of 75</i>			
<b>ENERGY EFFICIENT LIGHTING/ APPLIANCES</b>			
indoor fluorescent fixtures	2		
recessed light fixtures are compact fluorescents	2		
outdoor lighting controls	2		
high efficiency exterior lighting	2		
energy efficient dishwasher	1		
energy efficient refrigerator	2		
no garbage disposal	1		
<i>ENERGY EFFICIENT LIGHTING/ APPLIANCES SUBTOTAL</i>			
<b>RESOURCE EFFICIENT DESIGN</b>			
floor plan adheres to 2-ft dimensions	2		
interior living spaces adhere to 2-ft dimensions	1		
floor joists @ 24-in. centers (per floor)	3		
floor joists @ 19.2-in. centers (per floor)	2		
non-load bearing wall studs @ 24-in. centers	2		
all wall studs @ 24-in. centers	3		
window rough openings eliminate jack stud	2		
non-structural headers in non-load bearing walls	2		
single top plate with stacked framing	3		
2-stud corners with drywall clips or alternative framing	3		
T-walls with drywall clips or alternative framing	3		
<i>RESOURCE EFFICIENT DESIGN SUB TOTAL</i>			
<b>RESOURCE EFFICIENT BUILDING MATERIALS</b>			
<b>RECYCLED/ NATURAL CONTENT MATERIALS</b>			
concrete with fly ash	3		
insulation	1		
flooring	1		
carpet	1		
carpet pad	1		

	POINTS	WORKSPACE	FINAL
outdoor decking and porches	2		
air conditioner condensing unit pad	1		
<i>RECYCLED/ NATURAL CONTENT MATERIALS SUBTOTAL</i>			
<b>ADVANCED PRODUCTS</b>			
engineered floor framing	2		
engineered roof framing	2		
OSB roof decking	1		
non-solid sawn wood or steel beams	1		
non-solid sawn wood or steel headers	1		
engineered wall framing	1		
engineered interior trim	1		
engineered exterior trim including cornice	1		
steel interior walls	1		
Structural Insulated Panels (exterior walls)	5		
Structural Insulated Panels (roof)	3		
Precast Autoclaved Aerated Concrete	5		
Insulated Concrete Forms	5		
<i>ADVANCED PRODUCTS SUBTOTAL</i>			
<b>DURABILITY</b>			
roofing (min. 25-year warranty)	1		
roofing (min. 30-year warranty)	2		
roofing (min. 40-year warranty)	3		
subfloor decking (min. 40-year warranty)	1		
light roof color (asphalt or fiberglass shingles)	1		
light roof color (tile or metal)	2		
roof drip edge	1		
exterior cladding (min. 3 sides with 40-year warranty or masonry)	1		
walls covered with builder paper or housewrap (drainage plane)	1		
siding with vented rain screen	1		
back-primed siding and trim	1		
insulated glazing (min. 10-year warranty)	1		
window and door head flashing	1		
continuous foundation termite shield	1		
roof gutters that direct water away from foundation	1		
covered entry way	1		
<i>DURABILITY SUB TOTAL</i>			
<i>RESOURCE EFFICIENT BUILDING MATERIALS SUB TOTAL</i>			
<b>WASTE MANAGEMENT</b>			
<b>WASTE MANAGEMENT PRACTICES</b> *Builder must provide documentation (receipt) of donated materials			
job site framing plan and cut list	10		
central cut area	3		
*donation of excess materials or re-use (min. \$500/ job)	1		
<i>WASTE MANAGEMENT PRACTICES SUBTOTAL</i>			

	POINTS	WORKSPACE	FINAL
<b>RECYCLE CONSTRUCTION WASTE</b>			
<i>Builder can receive points for individual materials or additional points for waste management plan.</i>			
posted job site waste management plan—recycle 75% of 3 materials	5		
wood	3		
cardboard	1		
metal	1		
drywall (recycle or grind and spread on site)	3		
plastics	1		
shingles	1		
<i>RECYCLE CONSTRUCTION WASTE SUBTOTAL</i>			
<i>WASTE MANAGEMENT SUBTOTAL</i>			
<b>INDOOR AIR QUALITY</b>			
<b>COMBUSTION SAFETY</b>			
detached garage	5		
attached garage—seal bottom plate and penetrations to conditioned space	4		
attached garage—exhaust fan controlled by motion sensor or timer	2		
direct vent, sealed combustion fireplace	3		
furnace combustion closet isolated from conditioned area	4		
water heater combustion closet isolated or power vented	4		
carbon monoxide detector	4		
house depressurization test	4		
<i>COMBUSTION SAFETY SUBTOTAL</i>			
<b>MOISTURE CONTROL</b>			
drainage tile on top of footing	1		
drainage tile at outside perimeter edge of footing	2		
drainage board for below grade walls	4		
gravel bed beneath slab-on-grade floors	3		
vapor barrier beneath slab (above gravel) and in crawl space	2		
capillary break between foundation and framing	1		
<i>MOISTURE CONTROL SUBTOTAL</i>			
<b>VENTILATION</b>			
radon/soil gas vent system	3		
radon test of home prior to occupancy	2		
high efficiency, low noise bath fans	3		
tub/shower room fan controls	1		
kitchen range hood vented to exterior	3		
ceiling fans (minimum 3 fans)	1		
whole house fan	2		
controlled house ventilation (0.35 ACH)	4		
dehumidification system	3		
vented garage storage room	1		
no power roof vents	1		



	POINTS	WORKSPACE	FINAL
dampered fresh air intake	2		
<i>VENTILATION SUBTOTAL</i>			
<b>MATERIALS</b>			
no urea formaldehyde materials inside conditioned space	2		
urea formaldehyde materials inside conditioned space sealed	1		
low VOC paints, stains, finishes	1		
low VOC sealants and adhesives	1		
low VOC carpet	1		
alternative termite treatment	2		
central vacuum system	1		
filter/ air cleaner with minimum 30% dust spot efficiency	2		
protect ducts during construction	2		
<i>MATERIALS SUBTOTAL</i>			
<i>INDOOR AIR QUALITY SUBTOTAL</i>			
<b>WATER INDOOR</b>			
water filter (NSF certified)	1		
high efficiency clothes washer	2		
pressure reducing valve	1		
high efficiency plumbing fixtures	2		
hot water demand re-circulation	1		
shower drain heat recovery device	1		
water heater (Energy Star: gas 0.62, electric 0.92)	2		
water heater tank insulation	1		
pipe insulation	1		
heat traps	1		
heat recovery water heating	1		
solar domestic water heating	3		
heat pump water heater	2		
<i>WATER INDOOR SUB TOTAL</i>			
<b>WATER OUTDOORS</b>			
HBA WATER SMART program	5		
xeriscape resource	1		
xeriscape plan	4		
xeriscape installed	15		
timer on hose bibs or irrigation system	1		
efficient irrigation system (min. 50% plantings with drip system)	2		
greywater irrigation	3		
rainwater harvest system	3		
permeable pavement driveway/ parking area	1		
<i>WATER OUTDOORS SUBTOTAL</i>			
<b>HOMEBUYER EDUCATION/ OPPORTUNITIES</b>			
guaranteed energy bills	15		
review energy operations with homeowner	4		
review irrigation system operations manuals with home owner	2		

	POINTS	WORKSPACE	FINAL
built-in recycling center	2		
local recycling contact	1		
household hazardous waste resources	1		
environmental features checklist for walk-through	1		
<i>HOMEBUYER EDUCATION/ OPPORTUNITIES SUBTOTAL</i>			
<b>BUILDER OPERATIONS</b>			
builds 10% of total houses to EarthCraft House <sup>SM</sup> standards	3		
<b>OR</b> builds 80% of total houses to EarthCraft House <sup>SM</sup> standards	5		
markets EarthCraft House <sup>SM</sup> program	2		
environmental checklist provided to all subcontractors	1		
Certified Professional Home Builder	3		
uses HBA Homeowner Handbook for warranty standards	2		
<i>BUILDER OPERATIONS SUBTOTAL</i>			
<b>BONUS POINTS</b>			
site located within ¼ mile of mass transit	5		
sidewalk connects house to business district	5		
brownfield site	5		
solar electric system	25		
Alternative fuel vehicles: electric charging station or natural gas pump	5		
American Lung Association Health House <sup>®</sup>	5		
exceeds Energy Star (1 point for each 1%) for a maximum of 5			
Innovation Points — Builder submits specifications for innovative products or design features to qualify for additional points			
<i>BONUS POINTS SUBTOTAL</i>			
<b>EarthCraft House<sup>SM</sup> TOTALS</b>			
<i>SITE PLANNING</i>			
<i>ENERGY EFFICIENT BUILDING ENVELOPE AND SYSTEMS</i>			
<i>ENERGY EFFICIENT LIGHTING/ APPLIANCES</i>			
<i>RESOURCE EFFICIENT DESIGN</i>			
<i>RESOURCE EFFICIENT BUILDING MATERIALS</i>			
<i>WASTE MANAGEMENT</i>			
<i>INDOOR AIR QUALITY</i>			
<i>WATER-INDOOR</i>			
<i>WATER-OUTDOORS</i>			
<i>HOMEBUYER EDUCATION/ OPPORTUNITIES</i>			
<i>BUILDER OPERATIONS</i>			
<i>BONUS POINTS</i>			
<i>GRAND TOTAL</i>			

## ABOUT SOUTHFACE

Since 1978, the Southface Energy Institute has earned a national reputation for its education and research in energy, building science, and environmental technologies. Southface has received awards for excellence from the U.S. Department of Energy, the U.S. Environmental Protection Agency; the American Institute of Architects; the American Society of Heating, Refrigerating and Air-Conditioning Engineers; the American Concrete Institute; and the Georgia Environmental Council. Its work has been featured in consumer and professional publications, including *Southern Living*, *Popular Science*, *Good Cents Magazine*, *Environmental Design and Construction*, and *Home Energy*, as well as in national media ranging from CNN to the *Washington Post*. The Southface Environmental Resource Center functions as a multipurpose facility providing the Southeast with a building science learning lab and training facility, a networking hub for the sustainable building industry, a clearinghouse for sustainable technology information, and a meeting facility for a wide variety of groups including architects, builders, utilities, environmental and community development organizations, and many other public and private sector agencies. Further information on Southface is available on the web at [www.southface.org](http://www.southface.org).

## ABOUT THE BUILDINGS TECHNOLOGY CENTER

The Buildings Technology Center (BTC) at Oak Ridge National Laboratory is the premier U.S. research facility devoted to the development of technologies that improve the energy efficiency and environmental compatibility of residential and commercial buildings. The BTC is housed in a cluster of six buildings offering 20,000 square feet of space and state-of-the-art experimental facilities valued at more than \$6 million. A permanent staff of 50, continually supplemented by 10 to 20 guest researchers, operate the center. Annual program expenditures are about \$18 million.

The center's major areas of expertise focus on eight areas:

- heating and cooling equipment (vapor compression, absorption, and desiccants);
- thermal environmental engineering;
- envelope systems and materials (roofs, walls, foundations, insulation, and fenestration);
- building design and performance (Rebuild America, residential and commercial buildings research, and industrialized housing);
- state and community programs;
- the Federal Energy Management Program;
- communications and market outreach; and
- power systems and energy policy studies.

Established by the U.S. Department of Energy's Office of Building Technologies, the BTC is a designated National User Facility whose facilities are available to manufacturers, universities, and other organizations for proprietary and nonproprietary research and development. Further information is available on the center's web site at [www.ornl.gov/BTC](http://www.ornl.gov/BTC).